

Veritas™ Cluster Server Bundled Agents Reference Guide

Windows Server 2008 (x64),
Windows Server 2008 R2 (x64)

6.0

Veritas Cluster Server Bundled Agents Reference Guide

The software described in this book is furnished under a license agreement and may be used only in accordance with the terms of the agreement.

Product version: 6.0

Document version: 6.0.0.0

Legal Notice

Copyright © 2011 Symantec Corporation. All rights reserved.

Symantec, the Symantec Logo, Veritas, Veritas Storage Foundation, CommandCentral, NetBackup, Enterprise Vault, and LiveUpdate are trademarks or registered trademarks of Symantec Corporation or its affiliates in the U.S. and other countries. Other names may be trademarks of their respective owners.

This Symantec product may contain third party software for which Symantec is required to provide attribution to the third party ("Third Party Programs"). Some of the Third Party Programs are available under open source or free software licenses. The License Agreement accompanying the Software does not alter any rights or obligations you may have under those open source or free software licenses. See the Third-party Legal Notices document for this product, which is available online or included in the base release media.

The product described in this document is distributed under licenses restricting its use, copying, distribution, and decompilation/reverse engineering. No part of this document may be reproduced in any form by any means without prior written authorization of Symantec Corporation and its licensors, if any.

THE DOCUMENTATION IS PROVIDED "AS IS" AND ALL EXPRESS OR IMPLIED CONDITIONS, REPRESENTATIONS AND WARRANTIES, INCLUDING ANY IMPLIED WARRANTY OF MERCHANTABILITY, FITNESS FOR A PARTICULAR PURPOSE OR NON-INFRINGEMENT, ARE DISCLAIMED, EXCEPT TO THE EXTENT THAT SUCH DISCLAIMERS ARE HELD TO BE LEGALLY INVALID. SYMANTEC CORPORATION SHALL NOT BE LIABLE FOR INCIDENTAL OR CONSEQUENTIAL DAMAGES IN CONNECTION WITH THE FURNISHING, PERFORMANCE, OR USE OF THIS DOCUMENTATION. THE INFORMATION CONTAINED IN THIS DOCUMENTATION IS SUBJECT TO CHANGE WITHOUT NOTICE.

The Licensed Software and Documentation are deemed to be commercial computer software as defined in FAR 12.212 and subject to restricted rights as defined in FAR Section 52.227-19 "Commercial Computer Software - Restricted Rights" and DFARS 227.7202, "Rights in Commercial Computer Software or Commercial Computer Software Documentation", as applicable, and any successor regulations. Any use, modification, reproduction release, performance, display or disclosure of the Licensed Software and Documentation by the U.S. Government shall be solely in accordance with the terms of this Agreement.

Symantec Corporation
350 Ellis Street
Mountain View, CA 94043
<http://www.symantec.com>

Technical Support

Symantec Technical Support maintains support centers globally. Technical Support's primary role is to respond to specific queries about product features and functionality. The Technical Support group also creates content for our online Knowledge Base. The Technical Support group works collaboratively with the other functional areas within Symantec to answer your questions in a timely fashion. For example, the Technical Support group works with Product Engineering and Symantec Security Response to provide alerting services and virus definition updates.

Symantec's support offerings include the following:

- A range of support options that give you the flexibility to select the right amount of service for any size organization
- Telephone and/or web-based support that provides rapid response and up-to-the-minute information
- Upgrade assurance that delivers automatic software upgrades protection
- Global support purchased on a regional business hours or 24 hours a day, 7 days a week basis
- Premium service offerings that include Account Management Services

For information about Symantec's support offerings, you can visit our web site at the following URL:

www.symantec.com/business/support/index.jsp

All support services will be delivered in accordance with your support agreement

and the then-current enterprise technical support policy.

Contacting Technical Support

Customers with a current support agreement may access Technical Support information at the following URL:

www.symantec.com/business/support/contact_techsupp_static.jsp

Before contacting Technical Support, make sure you have satisfied the system requirements that are listed in your product documentation. Also, you should be at the computer on which the problem occurred, in case it is necessary to replicate the problem.

When you contact Technical Support, please have the following information available:

- Product release level
- Hardware information
- Available memory, disk space, and NIC information
- Operating system
- Version and patch level

- Network topology
- Router, gateway, and IP address information
- Problem description:
 - Error messages and log files
 - Troubleshooting that was performed before contacting Symantec
 - Recent software configuration changes and network changes

Licensing and registration

If your Symantec product requires registration or a license key, access our technical support web page at the following URL:

www.symantec.com/business/support/

Customer service

Customer service information is available at the following URL:

www.symantec.com/business/support/

Customer Service is available to assist with non-technical questions, such as the following types of issues:

- Questions regarding product licensing or serialization
- Product registration updates, such as address or name changes
- General product information (features, language availability, local dealers)
- Latest information about product updates and upgrades
- Information about upgrade assurance and support contracts
- Information about the Symantec Buying Programs
- Advice about Symantec's technical support options
- Nontechnical presales questions
- Issues that are related to CD-ROMs or manuals

Support agreement resources

If you want to contact Symantec regarding an existing support agreement, please contact the support agreement administration team for your region as follows:

Asia-Pacific and Japan	customercare_apac@symantec.com
Europe, Middle-East, and Africa	semea@symantec.com
North America and Latin America	supportsolutions@symantec.com

Documentation

Your feedback on product documentation is important to us. Send suggestions for improvements and reports on errors or omissions. Include the title and document version (located on the second page), and chapter and section titles of the text on which you are reporting. Send feedback to:

doc_feedback@symantec.com

About Symantec Connect

Symantec Connect is the peer-to-peer technical community site for Symantec's enterprise customers. Participants can connect and share information with other product users, including creating forum posts, articles, videos, downloads, blogs and suggesting ideas, as well as interact with Symantec product teams and Technical Support. Content is rated by the community, and members receive reward points for their contributions.

<http://www.symantec.com/connect/storage-management>

Contents

Chapter 1	Introducing VCS bundled agents	
	About VCS bundled agents	16
	Resources and their attributes	16
	Modifying agents and their resources	17
	Attributes	17
	Attribute data types	17
	Attribute dimensions	18
	Categories of bundled agents	19
	Storage agents	19
	Network agents	19
	FileShare agents	19
	Printshare agents	20
	Services and applications agents	20
	VCS infrastructure and support agents	20
	Which agents should I use?	21
Chapter 2	Storage agents	
	About Storage agents	24
	DiskReservation (DiskRes) agent	24
	Agent functions	25
	State definitions	25
	Resource type definition	25
	Attribute definitions	25
	Sample configuration	26
	Mount agent	28
	Dependency	28
	Agent functions	28
	State definitions	28
	Resource type definition	30
	Attribute definitions	30
	Sample configurations	32
	Volume Manager Diskgroup (VMDg) agent	33
	Agent functions	33
	State definitions	33
	Resource type definition	33

Attribute definitions	34
Sample configuration	37
MountV agent	38
Dependency	38
Agent functions	38
State definitions	39
Resource type definition	39
Attribute definitions	40
Sample configuration	43

Chapter 3 Network agents

About Network agents	46
NIC agent	46
Agent functions	46
State definitions	47
Resource type definition	47
Attribute definitions	48
Sample configuration	49
IP agent	50
Dependency	50
Agent functions	50
State definitions	50
Resource type definitions	50
Attribute definitions	51
Sample configuration	51
IPv6 agent	52
Dependency	52
Agent functions	52
State definitions	52
Resource type definition	53
Attribute definitions	53
Sample configuration	54
Lanman agent	55
Dependency	55
Agent functions	56
State definitions	56
Resource type definition	57
Attribute definitions	58
Sample configurations	69

Chapter 4 FileShare agents

About FileShare agents	72
------------------------------	----

FileShare agent	72
Dependencies	72
Agent functions	73
State definitions	73
About ForceControl function	74
Resource type definition	75
Attribute definitions	76
Sample configuration	83
CompositeFileShare agent	85
Dependencies	85
Agent functions	86
State definitions	86
About ForceControl function	86
Resource type definition	87
Attribute definitions	88
Sample configuration	96
Chapter 5 PrintShare agents	
About PrintShare agents	98
PrintSpool agent	98
Dependencies	98
Agent functions	99
State definitions	99
Resource type definition	99
Attribute definitions	99
Sample configuration	100
PrintShare agent	102
Dependency	102
Agent functions	102
State definitions	102
Resource type definition	102
Attribute definitions	103
Sample configuration	103
Chapter 6 Services and applications agents	
About services and application agents	106
Internet Information Services (IIS) agent	107
Agent functions	107
State definitions	107
Resource type definition	107
Attribute definitions	108
Sample configurations	111

GenericService agent	115
Agent functions	115
State definitions	115
Resource type definition	116
Attribute definitions	116
Sample configuration	118
ServiceMonitor agent	119
Agent functions	119
State definitions	119
Resource type definition	121
Attribute definitions	122
Sample configurations	124
Process agent	125
Agent functions	125
State definitions	125
Resource type definition	126
Attribute definitions	126
Sample configuration	131
MSMQ agent	132
Dependencies	132
Agent functions	132
State definitions	133
Resource type definition	133
Attribute definitions	133
Sample configuration	134

Chapter 7 VCS infrastructure and support agents

About VCS infrastructure and support agents	136
NotifierMngr agent	137
Agent functions	137
State definitions	137
Resource type definition	138
Attribute definitions	138
Sample configuration	141
Registry Replication (RegRep) agent	142
Dependency	142
Agent functions	142
State definitions	144
Resource type definition	144
Attribute definitions	145
Sample configuration	149
Proxy agent	151
Agent functions	151

State definitions	151
Resource type definition	151
Attribute definitions	152
Sample configurations	153
Phantom agent	154
Agent functions	154
State definitions	154
Attribute definitions	154
Sample configuration	154
FileNone agent	155
Agent functions	155
State definitions	155
Resource type definition	155
Attribute definitions	155
Sample configuration	155
ElifNone agent	156
Agent functions	156
State definitions	156
Resource type definition	156
Attribute definitions	156
Sample configuration	156
FileOnOff agent	157
Agent functions	157
State definitions	157
Resource type definition	157
Attribute definitions	157
Sample configuration	157
FileOnOnly agent	158
Agent functions	158
State definitions	158
Resource type definition	158
Attribute definitions	158
Sample configuration	158
RemoteGroup agent	159
Dependency	159
Agent functions	159
State definitions	160
Resource type definition	161
Attribute definitions	161
Sample scenario	168

Chapter 8

VCS hardware replication agent for NetApp

About hardware replication agents for NetApp	172
--	-----

NetApp Filer agent	173
Agent function	173
Resource type definition	173
Attribute definitions	173
Sample configuration	173
NetApp SnapDrive agent	175
Dependency	175
Agent functions	175
Resource type definition	175
Attribute definitions	176
Sample configuration	176
NetApp SnapMirror agent	177
Dependency	177
Agent functions	177
Action function	178
Resource type definition	178
Attribute definitions	179
Sample configuration	181

Chapter 9 Troubleshooting bundled agents

About troubleshooting bundled agents	184
VCS logging	184
Troubleshooting storage agents	185
Disk Reservation agent error messages	185
Mount agent error messages	190
Volume Manager (VMDg) agent error messages	198
MountV agent error messages	200
Troubleshooting network agents	204
NIC agent error messages	204
IP agent error messages	206
Lanman agent error messages	208
Troubleshooting FileShare agents	212
FileShare agent error messages	212
CompositeFileShare agent error messages	213
Troubleshooting PrintShare agents	216
PrintSpool agent error messages	216
PrintShare agent error messages	219
Troubleshooting services and application agents	221
IIS agent error messages	221
GenericService agent error messages	224
ServiceMonitor agent error messages	228
Process agent error messages	231
Troubleshooting infrastructure and support agents	236

Notifier Manager agent error messages	236
Registry Replication agent error messages	237
Proxy agent error messages	240
Phantom agent error message	240
FileNone agent error message	240
ElifNone agent error message	240
FileOnOff agent error messages	241
FileOnOnly agent error messages	241
Troubleshooting NetApp agents	242

Index	245
-------------	-----

Introducing VCS bundled agents

This chapter contains the following topics:

- [“About VCS bundled agents”](#) on page 16
- [“Resources and their attributes”](#) on page 16
- [“Modifying agents and their resources”](#) on page 17
- [“Attributes”](#) on page 17
- [“Categories of bundled agents”](#) on page 19
- [“Which agents should I use?”](#) on page 21

About VCS bundled agents

Bundled agents are VCS processes that manage resources of predefined resource types. The agents manage resources according to commands received from the VCS engine, HAD. Bundled agents are a part of VCS, and are installed when VCS is installed. A system has one agent per resource type that monitors all resources of that type; for example, a single IP agent manages all IP resources.

When the agent is started, it obtains the necessary configuration information from VCS. It then periodically monitors the resources, and updates VCS with the resource status.

Agents typically:

- Bring resources online.
- Take resources offline.
- Monitor resources and report state changes to VCS.

This document describes the VCS bundled agents along with their resource type definitions, attribute definitions, and sample configurations. The chapter on configuring resources and applications in the *Veritas Cluster Server Administrator's Guide* describes how to configure these agents.

Resources and their attributes

Resources are the key parts of a system and are known by their type, such as a disk, a volume, or an IP address. Resource types are defined in the `types.cf` file by a collection of attributes. The VCS configuration file, `main.cf`, contains the values for the resource attributes and has an `include` directive to the `types.cf` file.

There are three categories of resources: On-Off, On-Only, and Persistent. The category of a resource governs the functions that the corresponding agent performs. For example, if the resources of an agent are of type On-Off, the agent could online and offline the resources. If the resources of an agent are of type On-Only, the agent could online the resources but cannot offline them. For persistent resources, the agent can neither online nor offline a resource.

An attribute's given value configures the resource to function in a specific way. By modifying the value of a resource attribute, you can change the way the VCS agent manages the resource. For example, the IP agent monitors an IP address resource. The specific address to be monitored is identified by the attribute `Address` whose value is the specific IP address.

Modifying agents and their resources

Use Cluster Manager (Java Console), Cluster Management Console (Single Cluster Mode) also known as Web Console, or the VCS command line to dynamically modify the configuration of the resources managed by an agent. See the *Veritas Cluster Server Administrator's Guide* for instructions on how to complete these tasks.

Attributes

Configure VCS components with attributes. Attributes contain data about the cluster, systems, service groups, resources, resource types, agent, and heartbeats—if you want to use global clusters. Each attribute has a definition and a value. Some attributes also have default values.

Attribute data types

Table 1-1 Attribute Data Types

Data Type	Description
string	<p>Enclose strings, which are a sequence of characters, in double quotes ("). You do not have to enclose strings in quotes when they begin with a letter, and contains only letters, numbers, dashes (-), and underscores (_).</p> <p>For example:</p> <ul style="list-style-type: none">■ A string defining a network interface such <code>ashme0</code> does not require quotes as it contains only letters and numbers. Enclosing the string in double quotes is also acceptable—<code>"ashme0"</code>.■ A string defining an IP address requires quotes: <code>"100.101.102.1"</code> because the address contains periods. <p>A string can contain double quotes, but the quotes must be immediately preceded by a backslash. In a string, represent a backslash with two forward slashes (<code>\\</code>).</p>
integer	<p>Signed integer constants are a sequence of digits from 0 to 9. You can precede them with a dash. They are base 10. Integers cannot exceed the value of a 32-bit signed integer: 21471183247.</p>
boolean	<p>A boolean is an integer with the possible values of 0 (false) and 1 (true).</p>

Attribute dimensions

Table 1-2 Attribute Dimensions

Dimension	Description
scalar	A scalar has only one value. This is the default dimension.
vector	A vector is an ordered list of values. Each value is indexed using a positive integer beginning with zero. A set of brackets ([]) denotes that the dimension is a vector. Find the specified brackets after the attribute name on the attribute definition in the types.cf file.
keylist	A keylist is an unordered list of unique strings in that list.
association	An association is an unordered list of name-value pairs. An equal sign separates each pair. A set of braces ({}) denotes that an attribute is an association. Braces are specified after the attribute name on the attribute definition in the types.cf file, for example: <code>str SnmpConsoles{ }</code> .

Categories of bundled agents

Bundled agents are categorized according to the type of resources they make available.

Storage agents

Storage agents make your shared disks, disk groups, volumes, and mounts highly available.

- DiskReservation (DiskRes) agent—Monitors shared disks configured using Windows Disk Management.
- Mount agent—Monitors mount paths configured using Windows Disk Management.
- Volume Manager Diskgroup (VMDg) agent—Monitors shared disks configured using Storage Foundation for Windows (SFW).
- MountV agent—Monitors mount points configured on SFW-managed shared disks.
- NetAppSnapDrive agent—Monitors the Logical Unit Numbers (LUNs) on the NetApp Filers.
- NetAppFiler agent—Monitors the state of the NetApp Filers.

Network agents

Network agents make your IP addresses and computer names highly available.

- NIC Agent—Monitors a NIC (Network Interface Card).
- IP Agent—Monitors an IP address.
- Lanman Agent—Monitors a virtual computer name.

FileShare agents

Fileshare agents make shared directories and subdirectories highly available.

- FileShare Agent—Monitors a shared directory.
- CompositeFileShare Agent—Monitors multiple shared directories.

Printshare agents

The Printshare agents work together to make a shared network printer highly available.

- PrintSpool Agent—Monitors a print spooler.
- PrintShare Agent—Monitors a shared network printer.

Services and applications agents

Services and application agents make web sites, applications, generic services, and processes highly available.

- Microsoft Virtual Machine (MSVirtualMachine) Agent—Monitors virtual machines configured using Microsoft Virtual Server.
- Internet Information Services (IIS) Agent—Monitors IIS sites and services.
- GenericService Agent—Monitors generic services.
- ServiceMonitor Agent—Monitors a service or starts a user-defined script.
- Process Agent—Monitors a process.
- MSMQ Agent—Creates a MSMQ service for a MSMQ resource, brings the MSMQ resource online, takes it offline, and monitors its status.

VCS infrastructure and support agents

The VCS infrastructure and support agents provide high availability for VCS-related operations.

- NotifierMngr Agent—Monitors a notifier process.
- Registry Replication (RegRep) Agent—Synchronizes the registries of cluster nodes by monitoring changes to the registry of the active node.
- Proxy Agent—Monitors the state of a resource on a local or remote system.
- Phantom Agent—Determines the state of service groups having resources of type None only.
- RemoteGroup Agent—Monitors and manages service groups in a remote cluster.

You can use the following agents to test VCS functionality:

- ElifNone Agent—Monitors a file.
- FileNone Agent—Monitors a file.
- FileOnOff Agent—Creates a file, monitors it, and deletes it.
- FileOnOnly Agent—Creates and monitors a file.

Which agents should I use?

This information in the table enables you to decide which agent to use depending on the resource you want to make highly available.

Table 1-3 Resources and corresponding VCS agents

Resource to Make Highly Available	Agents to Use
Shared Storage Disks and volumes managed using SFW or Windows Logical Disk Manager or NetApp	In case of SFW, use VMDg and MountV In case of LDM, use DiskRes and Mount In case of a NetApp storage environment, use NetAppFiler and NetAppSnapDrive
IP address Adapter and the associated IP address	NIC, IP or IPv6
Computer name (virtual name)	Lanman
File shares	
Directory	Fileshare or CompositeFileShare
Shared printer	Printspool, Printshare
Sites configured using Internet Information Services (IIS)	IIS
Processes (*.pl, *.sh, *.exe, and *.bat)	Process
Windows service residing in the Service Control Manager (SCM)	GenericService or ServiceMonitor
Windows Registry	Registry Replication (RegRep)
Virtual machines configured using Microsoft Virtual Server	MSVirtualMachine
Service group in another cluster	RemoteGroup

Storage agents

This chapter contains the following topics:

- [“About Storage agents”](#) on page 24
- [“DiskReservation \(DiskRes\) agent”](#) on page 24
- [“Mount agent”](#) on page 28
- [“Volume Manager Diskgroup \(VMDg\) agent”](#) on page 33
- [“MountV agent”](#) on page 38

About Storage agents

Storage agents make your shared storage highly available.

- Use the Disk Reservation and Mount agents to provide high availability for shared disks and volumes managed using Windows Logical Disk Management (LDM).

Note: The Disk Reservation and Mount agents are not supported in an SFW environment.

- Use the Volume Manager Diskgroup (VMDg) and MountV agents to provide high availability for shared disks and volumes managed using Storage Foundation for Windows.

In case of a NetApp storage environment, the Logical Unit Numbers (LUNs) on the NetApp Filer are made highly available by the NetApp Filer and NetApp SnapDrive agents instead of the VMDg and MountV agents respectively.

See “[VCS hardware replication agent for NetApp](#)” on page 171 for more information on these agents.

DiskReservation (DiskRes) agent

The DiskReservation agent monitors shared disks. The agent also prevents data corruption caused by network partitioning, a condition in which two cluster systems provide the same services simultaneously. This condition occurs due to network link failure and may cause data corruption. The agent ensures only one cluster system holds persistent reservation to shared disks.

During a typical network partition, one system (SystemA) has the DiskRes resource online and holds reservation to shared disks. Another system (SystemB) attempts to come online and reserve the shared disks. To avoid network partitioning, SystemB issues a bus reset and waits for the interval specified in the GracePeriod attribute to determine if SystemA is functioning. If SystemA is functioning, SystemA reacquires reservation to the shared disks. Otherwise, SystemB attempts to reserve the shared disks. The system that gains reservation to the disks is designated owner of the resource, and the resource is brought online on that system.

By default, a system is designated owner of the resource if it reserves 80 percent of the shared disks. You can modify the agent’s configuration to change the ownership criteria.

Note: This agent is not supported in an SFW environment.

Agent functions

- **online**—Reserves the shared disks each second.
- **offline**—Releases the reservation to the shared disks.
- **monitor**—Verifies the system holds the reservation to the shared disks.

State definitions

- **ONLINE**—Indicates the system holds the reservation to the shared disks.
- **OFFLINE**—Indicates the system does not hold the reservation to the shared disks.
- **UNKNOWN**—Indicates the agent could not determine the status of the shared disks.

Resource type definition

```
type DiskRes (
  static i18nstr ArgList[] = { Signatures, ConfigPercentage,
    FailFastInterval, GracePeriod }
  str Signatures[]
  int ConfigPercentage = 80
  int FailFastInterval = 1
  int GracePeriod = 5
)
```

Attribute definitions

Table 2-1 DiskRes agent required attributes

Required Attribute	Type and Dimension	Description
Signatures	string-vector	An array specifying the signature of each SCSI disk. To retrieve the disk signature, use the VCS utility, "havol" with the "scsistest" option. See the <i>VCS Administrator's Guide</i> for instructions on how to use the utility.

Table 2-2 DiskRes agent optional attributes

Optional Attributes	Type and Dimension	Description
ConfigPercentage	integer-scalar	<p>The percentage of shared disks a system must reserve to be designated owner of the DiskRes resource. When a system acquires reservation to the number of disks that equals this value, the resource is brought online on the system.</p> <p>Set this attribute to at least 51 percent. If you set this attribute to a value less than 50 percent, the agent changes it to 51 percent. Default is 80 percent.</p> <p>Note: If you set this attribute to a value less than 51 percent, the agent internally treats it to be 51 percent. However, this is not updated in the GUI.</p>
FailFastInterval	integer-scalar	<p>Number of seconds the resource waits before bringing down the system after reservation fails. If during this interval the resource acquires reservation, it is not brought down. The resource is brought down in case of a reservation conflict, that is, if another system acquires reservation to the shared disks. Note that if a resource is brought down under these conditions, all service groups on the system might fail over to another system in the cluster.</p> <p>Default is 1 second.</p>
GracePeriod	integer-scalar	<p>Number of seconds the agent waits before taking over disk reservation after issuing a bus reset.</p> <p>Default is 5 seconds.</p>

Sample configuration

In the following example, the Disk Reservation agent is configured to monitor three shared disks. The resource is brought online on a system when it acquires reservation to all disks.

```
DiskRes DiskRes_A (
    Signatures = {2336572, 2336573, 2336574}
    ConfigPercentage = 100;
)
```

Note that if the shared disk is reserved by another application, the DiskReservation agent resets the disk reservation. If you use the command

`hastop -all -force` to stop HAD on a system, the system holds reservation to the disk even after HAD is stopped and the disk is not visible from any other system. To see the shared disk from other systems, bring down the DiskReservation resource gracefully, using the command `hastop -all`. You could also use the `havol` utility to remove the reservation on the shared disks. See the description of the `havol` utility in the *Veritas Cluster Server Administrator's Guide* for instructions.

Mount agent

The Mount agent brings a basic disk mount point online, monitors it, and takes it offline. When a shared disk fails over to another system, the Mount agent ensures that the new system accesses the volume in the same way it was accessed before failover. The Mount agent ensures a consistent device path by mounting the volume with the same mount path (drive letter) on the new system. The agent also ensures proper dismounting from a failed system when a resource or group is taken offline. When a disk partition is mounted, VCS creates an administrative share to enable remote administration of the disk. Note that the volume to be monitored using the Mount agent must not be mounted multiple times.

The Mount agent supports basic disks only. VCS supports dynamic disks configured and controlled by SFW. To mount and unmount dynamic disks, use the MountV agent described in “[MountV agent](#)” on page 38.

The Mount agent supports intelligent resource monitoring and uses Intelligent Monitoring Framework (IMF) for resource state change notifications. The agent uses the PnP notifications generated by the operating system. For example, PnP notifications are generated for volume arrival or departure, volume failure, and file system notifications.

For more information about IMF, refer to the *Veritas Cluster Server Administrator's Guide*.

Note: This agent is not supported in an SFW environment.

Dependency

The Mount resource depends on the DiskRes resource.

Agent functions

- **online**—Mounts the partition (assigns a drive letter or folder) at the specified mount path.
- **offline**—Unassigns the drive letter or folder and unmounts the partition.
- **monitor**—Verifies that the partition is accessible from the specified mount path.

State definitions

- **ONLINE**—Indicates the system can access the configured partition at the specified mount path.

- **OFFLINE**—Indicates the system cannot access the configured partition at the specified path.
- **UNKNOWN**—Indicates the agent could not determine the status of the resource.

Resource type definition

```

type Mount (
  static il8nstr ArgList[] = { MountPath, PartitionNo, Signature,
    ForceUnmount, ListApplications, AutoFSClean }
  il8nstr MountPath
  int PartitionNo
  str Signature
  str ForceUnmount = READ_ONLY
  boolean ListApplications = 1
  boolean AutoFSClean = 1
)

```

Attribute definitions

Table 2-3 Mount agent required attributes

Required Attributes	Type-Dimension	Description
MountPath	string-scalar	<p>The drive letter or path to an empty NTFS folder that will be assigned to the partition being mounted.</p> <p>When configuring a directory to host the mount, verify the following conditions:</p> <ul style="list-style-type: none"> ■ The configured path exists. ■ The directory is empty. ■ The volume on which the directory resides is NTFS-formatted. ■ The directory is not a system directory. <p>The attribute can be specified as <i>X</i>, <i>X:</i>, <i>X:\</i>, <i>X:\Directory</i>, or <i>X:\Directory\</i>.</p> <p>The options are valid only if editing the attribute from Cluster Manager (Java Console). If editing the configuration file <i>main.cf</i> directly, you must specify two slashes (\\) instead of one; for example, <i>X:\\Directory\</i>.</p> <p>Note: This attribute can take localized values.</p>
PartitionNo	integer-scalar	<p>The partition on the disk configured for mounting. Note that the base index for the partition number is 1. Default is 0. To retrieve the partition number use the VCS utility, “<i>havol</i>” with the “<i>getdrive</i>” option.</p> <p>See the description of the <i>havol</i> utility in the <i>VCS Administrator’s Guide</i> for instructions.</p>

Table 2-3 Mount agent required attributes

Required Attributes	Type-Dimension	Description
Signature	string-scalar	A system-specified disk identifier. To retrieve the disk signature, use the VCS utility, "havol" with the "getdrive" option. See the description of the havol utility in the <i>VCS Administrator's Guide</i> for instructions.

Table 2-4 Mount agent optional attributes

Optional Attributes	Type and Dimension	Description
AutoFSClean	boolean-scalar	If the agent detects corruption, this attribute defines whether the agent automatically cleans the file system by running <code>Chkdsk /X</code> on the volume being brought online. The value 1 indicates the agent cleans the file system. The value 0 indicates it does not. Note that cleaning a file system may result in loss of data. Default is 1.
ForceUnmount	string-scalar	Defines whether the agent unmounts the volume forcibly while the volume is being used by other applications. The attribute takes the following values: <ul style="list-style-type: none"> ■ NONE: The agent does not unmount volume if other applications are accessing it. ■ READ-ONLY: The agent gracefully unmounts the volume even if applications are accessing it. ■ ALL: The agent unmounts the volume irrespective of the type of access applications have to the volume. Default is <code>READ_ONLY</code> .
ListApplications	boolean-scalar	Defines whether the agent lists the applications accessing the volume while unmounting. Default is 1.

Sample configurations

The following example shows a DiskRes resource with one partition.

```
DiskRes Disk_0 (  
    Signatures = { 10003330 }  
)  
  
Mount MOUNT_W (  
    MountPath = W  
    PartitionNo = 1  
    Signature = 10003330  
)  
  
Mount_W requires Disk_0
```

The next example shows two DiskRes resources, with one disk mounted from the mount point of the other disk are configured. The mount point X is created for partition 1 of Disk 0. Mount resource MOUNT_USERDATA mounts partition 1 of Disk 1 at the mount path X:\USERS\DATA.

```
DiskRes Disk_0 (  
    Signatures = {10003330,398787651}  
)  
  
Mount MOUNT_X (  
    MountPath = X  
    PartitionNo = 1  
    Signature = 10003330  
)  
  
Mount MOUNT_USERDATA (  
    MountPath = "X:\\USERS\\DATA"  
    PartitionNo = 1  
    Signature = 398787651  
    ForceUnmount = 1  
    ListApplications = 1  
    AutoFSClean = 1  
)  
  
MOUNT_X requires Disk_0  
MOUNT_USERDATA requires MOUNT_X
```

Volume Manager Diskgroup (VMDg) agent

The Volume Manager Diskgroup agent imports, monitors, and deports a cluster disk group configured using Storage Foundation for Windows. The agent makes the disk group highly available. The Volume Manager Diskgroup agent supports dynamic multi-pathing (DMP) and works in a SAN environment. The agent is represented by the VMDg resource type.

The VMDg agent supports intelligent resource monitoring and uses Intelligent Monitoring Framework (IMF) for resource state change notifications. The agent relies on the disk group related PnP notifications raised by Storage Foundation for Windows (SFW). For example, SFW raises PnP notifications for disk group import and deport state change and for disk group access state change (read-only, read/write).

For more information about IMF, refer to the *Veritas Cluster Server Administrator's Guide*.

Note: Use this agent to manage volumes on disk groups configured using Storage Foundation for Windows. Do not use this agent if you use other software to manage shared storage.

Agent functions

- **online**—Imports the configured disk group.
- **offline**—Deports the configured disk group.
- **monitor**—Verifies that the configured disk group is imported.

State definitions

- **ONLINE**—Indicates the configured disk group is imported.
- **OFFLINE**—Indicates the configured disk group is not imported.
- **UNKNOWN**—Indicates the agent could not detect the disk group.

Resource type definition

```
type VMDg (
    static il8nstr ArgList[] = { DiskGroupName, ForceImport,
    ForceDeport, ListMountedVolumes, ListApplications, VxVMFailAction,
    VxVMRestartAttempts, DetailMonitorFreq, DGGuid, FastFailOver }
    static int IMF{} = { Mode=3, MonitorFreq=5, RegisterRetryLimit=3 }
    static il8nstr IMFRegList[] = { DiskGroupName, DGGuid }
    str DiskGroupName
```

```

boolean ForceImport = 0
boolean ForceDeport = 0
boolean ListMountedVolumes = 0
boolean ListApplications = 0
str VxObFailAction = RESTART_VXOB
int VxObRestartAttempts = 10
int DetailMonitorFreq = 10
str DGGuid
str VxVMFailAction = RESTART_VXVM
int VxVMRestartAttempts = 10
boolean FastFailOver = 0
)

```

Attribute definitions

Table 2-5 VMDg agent required attributes

Required Attribute	Type and Dimension	Description
DiskGroupName	string-scalar	The name of the cluster disk group configured using Storage Foundation. The disk group name may be retrieved from the SFW console by running the command <code>vxdg list</code> , or by using the VMGetDrive utility. See the description of the VMGetDrive utility in the <i>Veritas Cluster Server Administrator's Guide</i> for instructions.

Table 2-6 VMDg agent optional attributes

Optional Attributes	Type and Dimension	Description
DetailMonitorFreq	integer-scalar	The number of monitor cycles after which the agent monitors the resource in detail. Setting this value to 0 disables detail monitoring. Default is 10.

Table 2-6 VMDg agent optional attributes (Continued)

Optional Attributes	Type and Dimension	Description
DGGuid	string-scalar	The disk group ID of the cluster disk group configured using Storage Foundation. The disk group GUID may be retrieved by running the command <code>vxdg list</code> , or by using the VMGetDrive utility. See the description of the VMGetDrive utility in the <i>Veritas Cluster Server Administrator's Guide</i> for instructions.
ForceImport	boolean-scalar	<p>Defines whether the agent forcibly imports the disk group when exactly half the disks are available. The value 1 indicates the agent imports the configured disk group when half the disks are available. The value 0 indicates it does not. Default is 0. This means that the disk group will be imported only when SFW acquires control over majority of the disks.</p> <p>Note: Set this attribute to 1 only after verifying the integrity of your data. If due caution is not exercised before setting this attribute to 1, you risk a split-brain condition, leading to potential data loss.</p>
ForceDeport	boolean-scalar	<p>Defines whether the agent forcibly deports the disk group even if the disks within the disk group are being used. The value 1 indicates the agent forcibly deports disk groups. The value 0 indicates it does not. Default is 0.</p> <p>Note: Set this attribute to 1 only after verifying the integrity of your data. If due caution is not exercised before setting this attribute to 1, you risk a potential data loss.</p>

Table 2-6 VMDg agent optional attributes (Continued)

Optional Attributes	Type and Dimension	Description
ListApplications	boolean-scalar	<p>Defines whether the agent lists the applications accessing the disk group while deporting. The value 1 indicates the agent lists the applications. The value 0 indicates it does not. Default is 0.</p> <p>Note: The list of applications can be seen in the agent's log.</p>
ListMountedVolumes	boolean-scalar	<p>Defines whether the agent lists all mounted volumes in the disk group. The value 1 indicates the agent lists the mounted volumes. The value 0 indicates it does not. Default is 0.</p> <p>Note: The list of mounted volumes can be seen in the agent's log.</p>
VxObFailAction	string-scalar	<p>This attribute has been deprecated. Use VxVMFailAction instead.</p>
VxObRestartAttempts	integer-scalar	<p>This attribute has been deprecated. Use VxVMRestartAttempts instead.</p>
VxVMFailAction	string-scalar	<p>Defines the agent behavior when the Veritas Enterprise Administrator Service (VxSvc) fails.</p> <p>The value <code>RESTART_VXVM</code> indicates the agent attempts to restart the VxSvc service every monitor cycle.</p> <p>The value <code>SHUTDOWN</code> indicates the agent attempts to restart the VxSvc service the number of times defined in the attribute <code>VxVMRestartAttempts</code>.</p> <p>If it fails in restarting VxSvc, the agent restarts the system. When this occurs, all service groups online on the system fail over to another system in the cluster. For example, if <code>VxVMRestartAttempts</code> is set to 5, the agent attempts to start the service five times before restarting the system.</p> <p>Default is <code>RESTART_VXVM</code>.</p>

Table 2-6 VMDg agent optional attributes (Continued)

Optional Attributes	Type and Dimension	Description
VxVMRestartAttempts	integer-scalar	The number of times the agent attempts to restart the failed VxSvc service before restarting the system. This attribute is considered only when VxVMFailAction value is set to SHUTDOWN. Default is 10.
FastFailOver	boolean-scalar	This attribute decides whether or not a disk group is enabled for fast failover. The value 1 indicates that the agent enables fast failover for the configured disk group. The value 0 indicates that fast failover is disabled for the disk group. Default is 0.

Sample configuration

```
VMDg DG_VCSDG (  
  DiskGroupName = VCSDG  
  ListMountedVolumes = 1  
  DGGuid = fb69e244-930f-479e-b9f5-c54449fe2fc0)
```

MountV agent

The MountV agent mounts, monitors, and unmounts volumes on cluster disk groups imported using the Veritas Storage Foundation for Windows. The agent supports volumes formatted using the NTFS, FAT, and FAT32 file systems.

When a cluster disk group fails over to another system, the MountV agent ensures the new system accesses the volume in the same way it was accessed before failover. The MountV agent ensures a consistent device path by mounting the disk group with the same mount point (drive letter) on the new system. The agent also mounts a volume as an NTFS folder. The agent ensures proper dismounting from a failed system when a resource or group is taken offline. When a volume is mounted, VCS creates an administrative share to enable remote administration of the disk.

The agent performs a file system check when it brings the resource online. If a drive letter is already assigned to the volume, the agent skips the file system check, and declares the resource online. Note that the volume to be monitored using the MountV agent must not be mounted multiple times.

The MountV agent supports intelligent resource monitoring and uses Intelligent Monitoring Framework (IMF) for resource state change notifications. The agent uses the PnP notifications generated by the operating system. In addition, the agent also uses custom notifications generated by Storage Foundation for Windows (SFW). For example, PnP notifications are generated for volume arrival or departure, volume failure, and file system notifications.

For more information about IMF, refer to the *Veritas Cluster Server Administrator's Guide*.

Note: Use this agent to manage volumes on disk groups configured using Veritas Storage Foundation for Windows. Do not use this agent if you use other software to manage shared storage.

Dependency

The MountV resource depends on the VMDg resource.

Agent functions

- **online**—Mounts the volume as a drive letter or as an NTFS folder.
- **offline**—Unmounts the configured volume.
- **monitor**—Verifies the volume is mounted as per the configuration.

State definitions

- ONLINE—Indicates the configured volume is mounted and accessible.
- OFFLINE—Indicates the mounted drive is inaccessible.
- UNKNOWN—Indicates the agent could not determine the state of the configured volume.

Resource type definition

```
type MountV (  
  static il8nstr ArgList[] = {MountPath, VolumeName,  
    "VMDGResName:DiskGroupName", ForceUnmount, ListApplications,  
    AutoFSClean, "VMDGResName:DGGuid", PurgeStaleMountPoints,  
    CheckFSAccess }  
  il8nstr MountPath  
  str VolumeName  
  str VMDGResName  
  str ForceUnmount = READ_ONLY  
  boolean ListApplications = 0  
  boolean AutoFSClean = 1  
  str MountResName  
  boolean PurgeStaleMountPoints = 1  
  boolean CheckFSAccess = 0  
)
```

Attribute definitions

Table 2-7 MountV agent required attributes

Required Attributes	Type and Dimension	Description
MountPath	string-scalar	<p>The drive letter or path to an empty NTFS folder that will be assigned to the volume being mounted.</p> <p>When configuring a directory to host the mount, verify the following conditions:</p> <ul style="list-style-type: none"> ■ The configured path exists. ■ The directory is empty. ■ The volume on which the directory resides is NTFS-formatted. ■ The directory is not a system directory. <p>The attribute can be specified as <code>X</code>, <code>X:</code>, <code>X:\</code>, <code>X:\Directory</code>, or <code>X:\Directory\</code>.</p> <p>These options are valid only if editing the attribute from Cluster Manager (Java Console). If editing the configuration file <code>main.cf</code> directly, you must specify two slashes (<code>\\</code>) instead of one; for example, <code>X:\\Directory\\</code>.</p> <p>Note: This attribute can take localized values.</p>
VolumeName	string-scalar	<p>The name of the volume to be mounted. For example, the name could be <code>Raid1</code>, <code>Stripe2</code>, <code>Volume01</code>, etc. Use the <code>VMGetDrive</code> utility to retrieve the volume name. See the description of the <code>VMGetDrive</code> utility in the <i>Veritas Cluster Server Administrator's Guide</i> for instructions.</p>
VMDGResName	string-scalar	<p>The name of the Volume Manager Diskgroup (VMDg) resource on which the MountV resource depends.</p>

Table 2-8 MountV agent optional attributes

Optional Attributes	Type and Dimension	Description
AutoFSClean	boolean-scalar	<p>If the agent detects corruption, this attribute defines whether the agent automatically cleans the file system by running Chkdsk /X on the volume being brought online. The value 1 indicates the agent cleans the file system. The value 0 indicates it does not. Default is 1.</p> <p>The output of the Chkdsk /x command is stored at <code>%vcs_home%\log\Chkdsk_<MountVres name>.txt.</code></p> <p>Here, <code>%vcs_home%</code> is the default product installation directory, typically <code>C:\Program Files\Veritas\Cluster Server</code>.</p>
ForceUnmount	string-scalar	<p>Defines whether or not the agent unmounts the volume (gracefully or forcibly) when it is being used by other applications.</p> <p>The attribute can take the following values:</p> <ul style="list-style-type: none"> ■ NONE: The agent does not unmount the volume if an application is accessing it. ■ READ_ONLY: The agent gracefully unmounts the volume even if applications are accessing it. ■ ALL: The agent forcefully unmounts the volume irrespective of the type of access an application has. <p>Default is READ_ONLY.</p> <p>If you have enabled Intelligent Monitoring Framework (IMF) and fast failover in your cluster environment, Symantec recommends that you set this attribute value to ALL.</p> <p>This reduces the failover time as the agent does not require additional time to gracefully close the read-only handles on the volume.</p>

Table 2-8 MountV agent optional attributes

Optional Attributes	Type and Dimension	Description
ListApplications	boolean-scalar	<p>Defines whether the agent lists the applications accessing the volume while unmounting. The value 1 indicates that the agent lists the applications; the value 0 indicates that it does not.</p> <p>Default is 0.</p> <p>If you have enabled Intelligent Monitoring Framework (IMF) and fast failover in your cluster environment, Symantec recommends that you set this attribute value to 0.</p> <p>This reduces the failover time as the agent does not enumerate the applications that are accessing the volume.</p>
PurgeStaleMountPoints	boolean-scalar	<p>This attribute is applicable to a global cluster configuration. In case of a global fail over, this attribute defines whether the agent purges volume mount point (NTFS folder mounts) properties before bringing the folder mount points online on the remote cluster.</p> <p>The default value is 1, which means that the agent purges the volume mount point properties.</p>
CheckFSAccess	boolean-scalar	<p>Defines whether or not the agent performs file system access monitoring on volumes mounted using SFW.</p> <p>The default value is 0 (False), which means that the file system check is disabled.</p> <p>Note: This attribute replaces the MountV agent's CheckFSAccess function. The CheckFSAccess function is deprecated.</p>

Sample configuration

In the following configuration, the resource MountV_X is configured to mount the disk group VCSDG as a drive (X:). The resource MountV_X_Usrs_Data is configured to mount the disk group as a folder.

```
MountV MountV_X (  
    MountPath = X  
    VolumeName = Volume1  
    VMDGResName = DG_VCSDG  
)  
  
MountV MountV_X_Usrs_Data (  
    MountPath = "X:\\users\\data"  
    VolumeName = Raid1  
    VMDGResName = DG_VCSDG  
)  
  
VMDg DG_VCSDG  
    DiskGroupName = VCSDG  
    ForceDeport = 1  
    ListMountedVolumes = 1  
    ListApplications = 1  
)  
  
MountV_X_Usrs_Data requires MountV_X  
MountV_X requires DG_VCSDG
```

Network agents

This chapter contains the following topics:

- [“About Network agents”](#) on page 46
- [“NIC agent”](#) on page 46
- [“IP agent”](#) on page 50
- [“IPv6 agent”](#) on page 52
- [“Lanman agent”](#) on page 55

About Network agents

Network agents make IP addresses and computer names highly available.

- The NIC, IP, and IPv6 agents work together to make a virtual IP address highly available.
- The Lanman agent makes a virtual computer name highly available. The Lanman agent requires the IP agent for operation.

NIC agent

The NIC (Network Interface Card) agent monitors the configured NIC. Some NICs maintain their connection status in a system-defined variable. The NIC agent uses this variable to determine the status of the NIC resource. If the NIC does not maintain its connection status, the agent uses a 'ping' or a User Datagram Protocol (UDP) echo broadcast to determine the status of the resource.

Note: The NIC agent supports Internet Protocol Version 6 (IPv6) networks. However, the support is limited to mixed mode (IPv4 and IPv6) configurations only. The NIC agent does not work in a pure IPv6 network environment.

The NIC agent supports intelligent resource monitoring and uses Intelligent Monitoring Framework (IMF) for resource state change notifications. The agent relies on the network and hardware events raised by the operating system. For example, an event is raised when a network adapter is disabled.

For more information about IMF, refer to the *Veritas Cluster Server Administrator's Guide*.

Agent functions

- online—Not applicable.
- offline—Not applicable.
- monitor—If the NIC maintains its connection status, the agent reads the system-defined variable to determine the status of the resource. If the NIC does not maintain its connection status, the agent verifies that the NIC has been assigned an IP address, and sends a ping to all the hosts listed in the attribute PingHostList. The agent counts the number of packets received by the NIC before and after the ping. If the count increases, the resource is marked ONLINE. If the count remains unchanged, the agent broadcasts a UDP echo request to the address derived from the

administrative IP address and the associated subnet mask. The agent counts the number of packets received by the NIC before and after the broadcast. If the count increases, the resource is marked `ONLINE`. If the count remains the same or decreases, the resource is marked `FAULTED`.

The NIC agent also calculates the percentage of erroneous packets transmitted during each monitor interval. If this percentage exceeds the value in the `MaxTxErrorPercentage` attribute for the number of consecutive monitor intervals specified by the value in the `MaxTxErrInterval` attribute, the NIC resource is marked `FAULTED`.

State definitions

- `ONLINE`—Indicates the NIC resource is online.
- `FAULTED`—Indicates a problem with the NIC or that a network link failed.
- `UNKNOWN`—Indicates the agent encountered errors while monitoring the NIC resource.

Resource type definition

```
type NIC (  
    static il8nstr ArgList[] = {MACAddress, PingTimeoutMseconds,  
        MaxTxErrorPercentage, MaxTxErrInterval, UseConnectionStatus,  
        PingHostList }  
    str MACAddress  
    int PingTimeoutMseconds = 1000  
    int MaxTxErrorPercentage = 50  
    int MaxTxErrInterval = 10  
    boolean UseConnectionStatus = True  
    str PingHostList[]  
)
```

Attribute definitions

Table 3-1 NIC agent required attributes

Required Attribute	Type and Dimension	Description
MACAddress	string-scalar	The physical address of the NIC to be monitored. Note that this attribute is always local, that is, it is different for each system. Note: You can use the <code>ipconfig -all</code> command to retrieve the physical address of a NIC.

Table 3-2 NIC agent optional attributes

Optional Attributes	Type and Dimension	Description
MaxTxErrInterval	integer-scalar	The number of consecutive monitor intervals for which the percentage of erroneous packets should not exceed the value specified in <code>MaxTxErrorPercentage</code> . When this occurs, the NIC is declared <code>FAULTED</code> . Default is 10.
MaxTxErrorPercentage	integer-scalar	The threshold error percentage for the total packets sent between two consecutive monitor intervals. Default is 50.
PingHostList	string-vector	A list of hosts that are always reachable from the NIC. If the <code>UseConnectionStatus</code> attribute is set to 0, make sure the attribute <code>PingHostList</code> is not empty.
PingTimeoutMseconds	integer-scalar	The timeout interval, in milliseconds, for a ping. Default is 1000 milliseconds.

Table 3-2 NIC agent optional attributes (Continued)

Optional Attributes	Type and Dimension	Description
UseConnectionStatus	boolean-scalar	<p>Defines whether the NIC maintains its connection status. The value True indicates the NIC maintains its status. The value False indicates it does not. If this attribute is set to False, you must specify a value for the attribute PingHostList. Default is True.</p> <p>VCS provides a utility, "NICTest," which determines whether a NIC maintains its connection status. You can use the NICTest utility to determine whether or not this attribute is required. See the description of the NICTest utility in the <i>Veritas Cluster Server Administrator's Guide</i> for instructions.</p>

Sample configuration

In the following example, the NIC agent is configured to monitor the adapter with MAC address 00-B0-D0-31-7D-FA. The UseConnectionStatus attribute is set to False. The agent sends a ping to the hosts listed in the PingHostList attribute to determine the status of the NIC resource. If the percentage of erroneous packets transmitted exceeds 30 percent for three consecutive monitoring intervals, the NIC resource is marked FAULTED.

```
NIC NIC_RL20001 (  
  MACAddress = "00-B0-D0-31-7D-FA"  
  PingTimeOutMseconds = 500  
  MaxTxErrorPercentage = 30  
  MaxTxErrInterval = 3  
  UseConnectionStatus = False  
  PingHostList = { "172.16.1.19", "172.16.1.21" }  
)
```

IP agent

The IP agent assigns a virtual IP address to the network interface card (NIC), monitors the IP address, and removes it.

The IP agent supports intelligent resource monitoring and uses Intelligent Monitoring Framework (IMF) for resource state change notifications. The agent relies on the network and hardware events raised by the operating system. For example, an event is raised when an IP address becomes unavailable.

For more information about IMF, refer to the *Veritas Cluster Server Administrator's Guide*.

Dependency

The IP resource depends on the NIC resource.

Agent functions

- **online**—Assigns a unique virtual IP address to an empty slot on the NIC after verifying that the IP address is not being used by another system.
- **offline**—Removes the virtual IP address assigned to the NIC.
- **monitor**—Verifies that the specified virtual IP address is assigned to the NIC.

State definitions

- **ONLINE**—Indicates the specified virtual IP address is assigned to the NIC.
- **OFFLINE**—Indicates the specified virtual IP address is not assigned to the NIC.
- **UNKNOWN**—Indicates the agent encountered errors while monitoring the IP resource. This may be due to an invalid or incorrect configuration.
- **FAULTED**—Indicates that the agent was unable to bring the IP address online. This may be because the IP address was removed out of VCS control, or the IP address is already online on the network.

Resource type definitions

```
type IP (  
    static il8nstr ArgList[] = {Address, SubNetMask, MACAddress}  
    str Address  
    str SubNetMask  
    str MACAddress  
)
```

Attribute definitions

Table 3-3 IP agent required attributes

Required Attributes	Type and Dimension	Description
Address	string-scalar	A unique virtual IP address to be assigned to the NIC.
SubNetMask	string-scalar	The subnet mask associated with the IP address.
MACAddress	string-scalar	The physical address of the NIC to which the virtual IP address is assigned. Note that this attribute is always local, that is, it is different for each system. Note: Use the <code>ipconfig -all</code> command to retrieve the physical address of a NIC.

Sample configuration

Here's a sample configuration of an IP resource:

```
IP IP_192_168_100_20 (  
    Address = "192.168.100.20"  
    SubNetMask = "255.255.255.0"  
    MACAddress @SYSTEM1 = "00-60-08-08-BA-C4"  
    MACAddress @SYSTEM2 = "00-90-27-28-5A-7E"  
)
```

IPv6 agent

The IPv6 agent is designed specifically to support Internet Protocol Version 6 (IPv6). The agent assigns a virtual IPv6 address to the network interface card (NIC), monitors the IPv6 address, and removes it. The agent also monitors the associated IPv6 prefix on the NIC.

You can use this agent when you want to monitor a single IPv6 address on a single adapter. The IPv6 settings on the interface must be enabled with a physical (or administrative) base IPv6 address before you using it for virtual IPv6 addresses.

The IPv6 agent currently supports the following types of IPv6 addresses:

- Unicast addresses
Only Global Unicast and Unique Local Unicast addresses are supported.
- Automatic configuration
Only Stateless IPv6 address configuration is supported. Stateless addresses are based on the information received from the routers configured on the network.

Dependency

The IPv6 resource depends on the NIC resource.

Agent functions

- **online**—Retrieves the IPv6 address from the configured attributes, verifies that the IPv6 address is unique and not in use already on the network and then assigns the address to the NIC.
- **monitor**—Retrieves the IPv6 address from the configured resource and verifies that the IPv6 address is assigned to the NIC.
- **offline**—Removes the IPv6 address assigned to the NIC.
- **clean**—Removes the IPv6 address assigned to the NIC.

State definitions

- **ONLINE**—Indicates the specified virtual IPv6 address is assigned to the configured NIC.
- **OFFLINE**—Indicates the specified virtual IPv6 address is not assigned to the NIC.

- UNKNOWN—Indicates the agent encountered errors while monitoring the IPv6 resource. This may be due to an invalid or incorrect configuration, or an unsupported IPv6 address type.
- FAULTED—Indicates that the agent was unable to bring the IPv6 address online. This may be because the IPv6 address was removed out of VCS control, or the IPv6 address is already online on the network.

Resource type definition

```
type IPv6 (
  static i18nstr ArgList[] = { Address, Prefix, MACAddress }
  str Address
  str Prefix
  str MACAddress
)
```

Attribute definitions

Table 3-4 IPv6 agent required attributes

Required Attributes	Type and Dimension	Description
Address	string-scalar	<p>A unique virtual IPv6 address to be assigned to the NIC.</p> <p>Note: If you configure the IPv6 resource manually, then the IPv6 address that you specify for this attribute must not be a physical (or administrative) base IP of the cluster node.</p>
Prefix	string-scalar	<p>The prefix associated with the IPv6 address.</p> <p>The prefix is generally represented as:</p> <p><i>ipv6-address/prefix-length</i></p> <p>The <i>ipv6-address</i> variable represents the IPv6 address that follows general IPv6 addressing rules (refer to RFC 2373 for details). The <i>prefix-length</i> variable is a decimal value that indicates the number of leftmost contiguous higher order bits of the address that make up the network portion of the address.</p> <p>Example:</p> <p>2001:db8:0:1::/64</p>

Table 3-4 IPv6 agent required attributes

Required Attributes	Type and Dimension	Description
MACAddress	string-scalar	The physical address of the NIC to which the virtual IPv6 address is to be assigned. Note that this attribute is always local, that is, it is different for each system. Note: Use the <code>ipconfig -all</code> command to retrieve the physical address of a NIC.

Sample configuration

Here's a sample configuration of an IPv6 resource:

```
IPv6 IPRes (  
    Address = "2001:db8:0:1:d78:341e:2f7c:5879"  
    Prefix = "2001:db8:0:1::/64"  
    MACAddress @SYSTEM1= 00-50-56-9F-53-DE  
    MACAddress @SYSTEM2 = 00-10-18-10-CB-1F  
    MACAddress @SYSTEM3 = 00-10-18-10-CA-DC  
)
```

Lanman agent

The Lanman agent enables clients to access data and applications on a cluster node by associating the virtual IP address with the virtual computer name in the WINS database. The agent provides the option of associating multiple IP addresses from different subnets with the virtual computer name. The agent also provides the option of creating the virtual computer object in any organizational unit in the Active Directory and enhances the DNS updating capabilities of VCS.

The Lanman agent registers the following services with the WINS server:

- Server (20h)
- Workstation (00h)
- Messenger (03h)

In an IPv6 environment, the Lanman agent relies on the DNS records to check for duplicate server names on the network. If the DNS entry for a virtual server name that uses an IPv6 address does not exist, the agent fails to validate the server for name duplication on the network. If the virtual IP is an IPv6 address, you must specify the DNS server IP address, either in the network adapter properties or in the Lanman agent's `AdditionalDNSServers` attribute.

The agent supports Kerberos authentication by providing the option of adding the virtual computer name to the Active Directory and adding the virtual IP address to the DNS. The agent uses the VCS Helper Service user context for AD and DNS updates.

The Lanman agent updates and monitors the canonical name (CNAME) mapping in the domain name server when failing over applications across subnets (performing a wide-area failover.) The Lanman agent also supports creating DNS records in different DNS zones.

DNS scavenging affects virtual servers configured in VCS because the Lanman agent uses DDNS to map virtual names with IP addresses. If you use scavenging, then you must set the `DNSRefreshInterval` attribute. This will enable the Lanman agent to refresh the resource records on the DNS servers. See the `DNSRefreshInterval` attribute description for more information.

If security policies are enabled on Windows Server 2008, ensure that the startup type of the Server Service is set to Automatic.

Dependency

The Lanman resource depends on the IP (in case of IPv4) and IPv6 (incase of IPv6) resource.

If you change your Lanman resource dependency to a new IP resource and bring the Lanman resource online, a ping to the virtual name might respond from the IP address of the previous IP resource until the next WINS broadcast. The WINS broadcast updates the WINS database with the changed association.

For example, if you took the Lanman resource offline, changed the Lanman resource dependency from IP_A to IP_B, and brought the Lanman resource online, a ping to the virtual name might still respond from IP_A. Note that the IP_A resource is kept online during this process. The ping will respond from IP_B after the next WINS broadcast updates the WINS database.

Agent functions

Online	Binds the IP addresses with the specified virtual computer name. The agent also queries the name server of the domain for Host (A), PTR, and CNAME records and adds or updates the records on the name server .
Offline	Removes the IP address binding from the virtual computer name.
Monitor	Verifies the IP addresses are bound to the virtual computer name. If DNSUpdateRequired and DNSRefreshRequired is enabled and the resource is online, then the Lanman agent refreshes the resource records on the DNS servers. The agent queries the name servers for DNS records. It reports back ONLINE if the response from all the name servers contains the Host (A), PTR, and CNAME records. If no servers return the appropriate records, the monitor reports the resource as OFFLINE.

State definitions

ONLINE	Indicates the IP addresses are bound to the virtual computer name and the DNS records are as expected.
OFFLINE	Indicates the IP addresses are not bound to the virtual computer name or the agent failed to create the DNS records or the expected DNS records were not found.
UNKNOWN	Indicates the agent could not determine the status of the resource.

Resource type definition

```
type Lanman (  
    static keylist LogDbg = {DBG_21}  
    static i18nstr ArgList[] = {VirtualName,  
    MultiNet, "IPResName:Address", "IPResName:SubNetMask",  
    "IPResName:MACAddress", "IPResName:Prefix", MultiNetInfo,  
    DNSUpdateRequired, ADUpdateRequired, DNSCriticalForOnline,  
    ADCriticalForOnline, ADContainer, DNSOptions,  
    AdditionalDNSServers, DNSRefreshInterval, DNSZones, AliasName,  
    TSIGKeyFile, TTL}  
    str VirtualName  
    str IPResName  
    boolean MultiNet = 0  
    str MultiNetInfo[]  
    boolean DNSUpdateRequired = 0  
    boolean ADUpdateRequired = 0  
    boolean DNSCriticalForOnline = 0  
    boolean ADCriticalForOnline = 0  
    str ADContainer  
    str DNSOptions[]  
    str AdditionalDNSServers{}  
    int DNSRefreshInterval = 0  
    str DNSZones{}  
    str AliasName = ""  
    str TSIGKeyFile = ""  
    int TTL = 0  
)
```

Attribute definitions

Table 3-5 Lanman agent required attributes

Required Attributes	Type and Dimension	Description
IPResName	string-scalar	The name of the IP resource on which the Lanman resource depends. Do not define a value for this attribute if the MultiNet attribute is set to 1.
VirtualName	string-scalar	The virtual computer name to be assigned to the server. The virtual name must be fewer than 15 characters. Note that if you specify a virtual computer name in lowercase letters, the agent converts it to uppercase. For example, the name VCSServer is converted to VCSSERVER.

Table 3-6 Lanman agent optional attributes

Optional Attributes	Type and Dimension	Description
ADContainer	string-scalar	<p>Specifies the distinguished name of the Active Directory container or the organizational unit (OU) for the newly created computer object. If no value is specified for this attribute, the Lanman resource creates the computer object in the default container "Computers."</p> <p>Note that the user account for VCS Helper service must have adequate privileges on the specified container to create and update computer accounts.</p> <p>Refer to Microsoft documentation for information on assigning user privileges for a container.</p> <p>By default, the attribute contains no value.</p> <p>Note: Value specified for this attribute will be effective only if ADUpdateRequired is set to 1.</p>

Table 3-6 Lanman agent optional attributes (Continued)

Optional Attributes	Type and Dimension	Description
ADCriticalForOnline	boolean-scalar	Defines whether the Lanman resource faults if the agent fails to update the Active Directory. The value 1 indicates that the resource faults in case of a failure to update the Active Directory. The value 0 indicates that it does not. Default is 0.

Table 3-6 Lanman agent optional attributes (Continued)

Optional Attributes	Type and Dimension	Description
AdditionalDNSServers	string-association	<p>An array that specifies the IP addresses of the additional DNS servers that will be updated by the Lanman resource. For all the Windows DNS servers, the forward and reverse lookup zones must be configured. For all the Berkeley Internet Name Domain (BIND) servers, only the forward lookup zones are required.</p> <p>All additional DNS servers are considered as Windows DNS servers by default. If any additional DNS server is a Berkeley Internet Name Domain (BIND) server, you will have to specify it in the attribute value.</p> <p>Example:</p> <pre>{“10.212.108.9” = ““, “10.212.108.10” = “BIND”}</pre> <p>Where 10.212.108.9 is the IP address of a Windows DNS server, and 10.212.108.10 is the IP address of a BIND DNS server.</p> <p>By default, the attribute contains no value. Values specified for this attribute will be effective only if DNSUpdateRequired is set to 1.</p> <p>The Lanman agent creates only CNAME records on BIND servers. You must also specify the AliasName attribute in case of BIND server updates.</p> <p>Note: The Lanman agent supports BIND version 8 and above.</p> <p>Note: In cases where the default DNS is a BIND DNS server, set the value of the DNSOptions attribute to IgnoreDefault, and specify the BIND DNS server details in this attribute.</p> <p>Note: If the BIND DNS servers are configured for secure updates, then you must configure the TSIG keys either in the DNSZones attribute or the TSIGKeyFile attribute.</p>

Table 3-6 Lanman agent optional attributes (Continued)

Optional Attributes	Type and Dimension	Description
ADUpdateRequired	boolean-scalar	Defines whether the Lanman resource updates the Active Directory with the virtual name. The value 1 indicates that the agent updates the Active Directory. The value 0 indicates it does not. Default is 0.
DNSCriticalForOnline	boolean-scalar	Defines whether the Lanman resource faults if the agent fails to update the DNS. The value 1 indicates that the resource faults in case of a failure to update the DNS. The value 0 indicates that it does not. Default is 0. In case of an IPv6 environment this attribute has no effect on the Lanman agent behavior. Even if this attribute is set to 0, the Lanman resource faults if the agent is unable to update the DNS.

Table 3-6 Lanman agent optional attributes (Continued)

Optional Attributes	Type and Dimension	Description
DNSOptions	string-vector	<p>An array that specifies the way in which the Lanman resource updates the DNS servers.</p> <p>This attribute can take one or all of the following values:</p> <ul style="list-style-type: none"> ■ UpdateAll: Updates all the default DNS servers specified in the TCP/IP properties for the cluster node, and the additional DNS servers specified in the AdditionalDNSServers attribute. ■ IgnoreDefault: Ignores the default DNS servers and updates only the additional DNS servers. ■ PurgeDuplicate: Removes duplicate DNS entries from the DNS servers. Symantec recommends you set this value for service groups configured for wide area failover. ■ SkipPtrRecords: The Lanman resource excludes the PTR records while updating the resource records on the specified DNS servers. <p>Any combination of these values can be specified for the attribute. This attribute takes effect only when the Lanman resource comes online.</p> <p>See “Updating DNS servers” on page 68 for more information.</p> <p>By default, the attribute contains no value. Values specified for this attribute will be effective only if DNSUpdateRequired is set to 1 and additional DNS servers are specified in the AdditionalDNSServers attribute.</p> <p>Note: In cases where the default DNS is a BIND DNS server, set this attribute value to IgnoreDefault, and specify the BIND DNS server details in the AdditionalDNSServers attribute.</p>

Table 3-6 Lanman agent optional attributes (Continued)

Optional Attributes	Type and Dimension	Description
DNSUpdateRequired	boolean-scalar	<p>Defines whether the Lanman resource updates the DNS with the virtual IP address. The value 1 indicates that the resource updates the DNS. The value 0 indicates it does not.</p> <p>Default is 0.</p> <p>If you set this attribute but there are no DNS servers specified in the TCP/IP properties, then you must specify the DNS servers that you wish to update in the AdditionalDNSServers attribute.</p> <p>If NetBios is disabled over TCP, set this attribute value to 1.</p> <p>In case of an IPv6 environment this attribute has no effect on the Lanman agent behavior. Even if this attribute is set to 0, the Lanman agent updates the DNS with the virtual IPv6 address entry by default.</p> <p>Note: If the virtual IP is an IPv6 address, you must specify the DNS server IP address, either in the network adapter properties or in the Lanman agent's AdditionalDNSServers attribute.</p> <p>Note: The Lanman resource does not update the DNS for the manual DNS entries.</p> <p>See “Updating manual DNS entries” on page 67 for more information.</p>

Table 3-6 Lanman agent optional attributes (Continued)

Optional Attributes	Type and Dimension	Description
DNSRefreshInterval	integer-scalar	<p>This attribute represents the time interval, in seconds, after which the Lanman agent attempts to refresh the resource records (RRs) on the DNS servers. You must set a value for this attribute if you want the Lanman agent to refresh the records on the DNS servers.</p> <p>The default value zero indicates that the Lanman agent does not attempt to refresh the records on the DNS servers.</p> <p>The Lanman agent logs warning messages if it is not able to refresh the DNS records. After 3 failed attempts, the Lanman agent logs error messages for subsequent failures.</p> <p>If the Lanman agent is unable to refresh the DNS records, and the records are removed as a result of a scavenging operation or by the DNS administrator, the Lanman resource will fault.</p>

Table 3-6 Lanman agent optional attributes (Continued)

Optional Attributes	Type and Dimension	Description
DNSZones	string-association	<p>An array that specifies a list of DNS zones (in case of multi-domain environments with parent-child configurations) for which the Lanman resource should create and update Address (A) records and canonical name (CNAME) records in the DNS server of the parent domain.</p> <p>Example: {"child1.company.com", "child2.company.com"}</p> <p>Where child1.company.com and child2.company.com are DNS zones representing different child domains.</p> <p>By default, the attribute contains no value. This means that the Lanman agent will create and update resource records only in the DNS name servers for the zones in which the nodes exist.</p> <p>If multiple zones are being updated on BIND DNS servers that are configured for secure updates, then each zone may require a different TSIG key. In such a case, you must specify the absolute path of the TSIG key file in the attribute value.</p> <p>Example:</p> <pre>{"child1.company.com" = "C:\TSIGKey1.key", "child2.company.com" = "C:\TSIGKey2.key"}</pre> <p>Where TSIGKey1.key is the TSIG key for the DNS zone child1.company.com, and TSIGKey2.key is the TSIG key for the DNS zone child2.company.com.</p> <p>Note: The Lanman agent supports BIND version 8 and above.</p> <p>See "TSIGKeyFile" on page 66 for more information on TSIG keys.</p>

Table 3-6 Lanman agent optional attributes (Continued)

Optional Attributes	Type and Dimension	Description
AliasName	string-scalar	<p>A string representing the alias to the canonical name. The Lanman agent creates a CNAME record using the value specified in this attribute.</p> <p>Example: “www”</p> <p>Where www is the alias to the canonical name mtv.veritas.com.</p> <p>By default, the attribute contains no value.</p> <p>Note: This attribute is required if a BIND DNS server is specified in the AdditionalDNSServers attribute.</p>
TSIGKeyFile	string-scalar	<p>Required when you configure BIND DNS for secure updates. Specify the absolute path to the file that contains the private Transaction Signature (TSIG) key. This key is used by the nsupdate utility to perform secure BIND DNS updates.</p> <p>See the BIND man pages for more information about secure DNS updates.</p> <p>You must copy the files containing the keys (typically the .key and the .private file) on each of the nodes that is listed in the service group's SystemList.</p> <p>By default, the attribute contains no value.</p> <p>Example: C:\TSIG\Kveritas.com.+157+00000.key</p> <p>Note: The Lanman agent supports BIND version 8 and above.</p>
TTL	integer-scalar	<p>This value defines the Time To Live (TTL) value (in seconds) that gets stored in the DNS records created by the agent.</p> <p>Default: 0</p> <p>Example: TTL = 7200</p>

Table 3-6 Lanman agent optional attributes (Continued)

Optional Attributes	Type and Dimension	Description
MultiNet	boolean-scalar	<p>Defines whether the Lanman resource binds multiple IP addresses with the virtual name. The value 1 indicates the resource binds multiple IP addresses specified in MultiNetInfo with the virtual computer name. The value 0 indicates the resource binds a single IP address specified in IResName.</p> <p>Default is 0.</p>
MultiNetInfo	string-vector	<p>An array that specifies details of the IP addresses to be bound to the virtual computer name. If MultiNet is set to 1, configure this attribute in the following format:</p> <pre>MultiNetInfo = { " IP=<i>ip_address1</i> Mask=<i>subnetmask1</i> WINS=<i>wins_ip_address1</i> MACAddress=<i>macaddress1</i> " , " IP=<i>ip_address2</i> Mask=<i>subnetmask2</i> WINS=<i>wins_ip_address2</i> MACAddress=<i>macaddress2</i> " }</pre> <p>Note: Specifying Mask and MACAddress is optional. If not specified, the Lanman agent discovers the subnet mask from the current configuration.</p> <p>Note: MACAddress is required if netbios is disabled for the IP address, on Windows Server 2008 only.</p>

Updating manual DNS entries

Perform the following steps to update the DNS for manual DNS entries.

To update the DNS for manual DNS entries

- 1 For the manually added DNS entry, add the user in whose context the VCS Helper service is running.
- 2 Assign “Full Control” privilege to the newly added user.

Refer to Microsoft documentation for information about adding users and assigning privileges.

Updating DNS servers

[Table 3-7](#) presents possible combinations of values for the DNSOptions attribute and the updates effected by the Lanman resource corresponding to each value set.

Table 3-7 DNSOptions attribute and Lanman agent behavior

UpdateAll	Ignore Default	Purge Duplicate	Effect
-	-	-	Updates any one default DNS server.
-	-	✓	Updates any one default DNS server and removes duplicate entries, if any.
-	✓	-	Updates any one additional DNS server.
-	✓	✓	Updates any one additional DNS server and removes duplicate entries, if any.
✓	-	-	Updates all the default and additional DNS servers.
✓	-	✓	Updates all the default and additional DNS servers and removes duplicate entries, if any.
✓	✓	-	Updates all the additional DNS servers.
✓	✓	✓	Updates all additional DNS servers and removes duplicate entries, if any.

Sample configurations

In the following example, the Lanman agent is configured to bind a single IP address with the virtual computer name VNAMEX1. The Lanman agent will also add the computer object to the specified Active Directory container and update the additional DNS servers.

```
IP VIP1 (  
  Address = "172.29.9.159"  
  SubNetMask = "255.255.254.0"  
  MACAddress @SYSTEM1 = "00-B0-D0-AB-4E-22"  
  MACAddress @SYSTEM2 = "00-B0-D0-D1-69-7D"  
)  
  
Lanman VNAMEX1 (  
  VirtualName = VNAMEX1  
  IPResName = VIP1  
  ADContainer = "OU=myUnit,DC=myCompany,DC=com"  
  DnsOptions = { UpdateAll, PurgeDuplicate }  
  AdditionalDNSServers = {"10.212.100.20", "10.212.100.21"}  
)  
  
VNAMEX1 requires VIP1
```

In the next example, the Lanman agent is configured to bind multiple IP addresses with the virtual computer name VNAMEX1.

```
IP IP_RES1 (  
  Address = "11.212.96.182"  
  SubNetMask = "255.255.254.0"  
  MACAddress @SYSTEM3 = "00-D0-B7-4A-03-D8"  
  MACAddress @SYSTEM4 = "00-D0-B7-4A-04-19"  
)  
  
IP IP_RES2 (  
  Address = "11.212.99.214"  
  SubNetMask = "255.255.254.0"  
  MACAddress @SYSTEM3 = "00-D0-B7-4A-03-71"  
  MACAddress @SYSTEM4 = "00-D0-B7-4A-03-7D"  
)  
  
Lanman LANMAN_VNAMEX1 (  
  VirtualName = VNAMEX1  
  MultiNet = 1  
  MultiNetInfo = {  
    "IP=11.212.96.182 MASK=255.255.254.0  
    MACAddress=00-D0-B7-4A-03-D8 WINS=10.212.100.120",  
    "IP=11.212.99.214 MASK=255.255.254.0  
    MACAddress=00-D0-B7-4A-03-D8 WINS=10.212.100.120" }  
)
```

```
NIC NIC-EXCH_GRP1 (  
    MACAddress @SYSTEM3 = "00-D0-B7-4A-03-D8"  
    MACAddress @SYSTEM4 = "00-D0-B7-4A-04-19"  
)  
  
NIC NIC-EXCH_GRP2 (  
    MACAddress @SYSTEM3 = "00-D0-B7-4A-03-71"  
    MACAddress @SYSTEM4 = "00-D0-B7-4A-03-7D"  
)  
  
IP_RES1 requires NIC-EXCH_GRP1  
IP_RES2 requires NIC-EXCH_GRP2  
LANMAN_VNAMEX1 requires IP_RES2  
LANMAN_VNAMEX1 requires IP_RES1
```

FileShare agents

This chapter contains the following topics:

- [“About FileShare agents”](#) on page 72
- [“FileShare agent”](#) on page 72
- [“CompositeFileShare agent”](#) on page 85

About FileShare agents

FileShare agents make file shares highly available. The FileShare agents include the FileShare and the CompositeFileShare agent. The FileShare agent ensures high availability for a shared folder and its subfolders. The CompositeFileShare agent ensures high availability for multiple subfolders.

FileShare agent

The FileShare agent enables systems to share a folder and its subfolders, making the shared folder highly available. The folder to be shared is stored on a shared disk.

Using the FileShare agent you can also do the following:

- Create hidden shares for a specific share or subfolders.
- Dynamically share subfolders created after the resource was brought online.
- Configure and control existing shares.

The FileShare agent enables sharing folders shared outside VCS. However, you cannot add special shares (shares created by the operating system for administrative and system use) to the VCS configuration. For example, you cannot add the shares ADMIN\$, print\$, IPC\$, and *DriveLetter*\$ to the VCS configuration.

You can configure a file share service group using the File Share Configuration Wizard. See the *Veritas Cluster Server Administrator's Guide* for instructions.

To share multiple subfolders, use the CompositeFileShare agent.

See "[CompositeFileShare agent](#)" on page 85.

Dependencies

The FileShare resource depends on the MountV resource. A FileShare service group also requires a Lanman resource that is dependent on the IP resource, as illustrated in the following dependency graph.

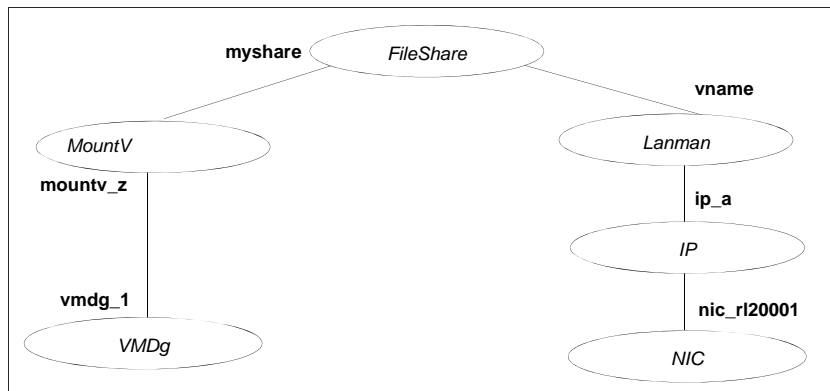
Figure 4-1 File Share service group dependency graph

Note: In case of a NetApp storage environment, use the NetApp Filer and NetApp SnapDrive agents instead of the VMDg and MountV agents respectively. If you are using Logical Disk Management (LDM) for configuring your storage, use the Mount and the DiskRes agents.

Agent functions

Online	Shares the specified folders with designated permissions.
Offline	Removes the shares for the specified folders.
Monitor	Verifies at least one specified folder is shared with the designated permissions.

State definitions

ONLINE	Indicates at least one specified folder is shared.
OFFLINE	Indicates no specified folder is shared.
UNKNOWN	Indicates the agent could not determine the status of the resource.

Note: Sharing a folder with a large number of subfolders and enabling the `ShareSubdirectories` attribute may cause increased failover time and high CPU and memory utilization.

About ForceControl function

ForceControl is a FileShare agent function that allows you to reset the file share properties as per what is defined in the VCS configuration. The agent overwrites all modifications made to the file share properties, either externally or from within VCS, and sets the properties as per what you had defined while configuring the file shares in VCS. This function overrides the FileShare agent's AutoControl attribute settings.

You can run the ForceControl function from the command line. To run the ForceControl function on a fileshare resource, type the following command:

```
hares -action <fileshare_resource_name> ForceControl  
-sys <system_name>
```

Here, `<fileshare_resource_name>` is the name of the file share resource for which you want to reset the properties and `<system_name>` is the name of the cluster node on which that file share resource is online.

For example, to run the ForceControl function on a FileShare resource `A_fileshare` that is currently online on a cluster node `Node1`, type the following:

```
hares -action A_fileshare ForceControl -sys Node1
```

The changes take effect on the next agent monitor function.

Resource type definition

```
type FileShare
static keylist SupportedActions = { ForceControl }
static il8nstr ArgList[] = { PathName, ShareName,
"LanmanResName:VirtualName", MaxUsers, "MountResName:MountPath",
HiddenShare, ShareSubdirectories, HideChildShares, AutoShare,
AutoControl, ClientCacheType, UserPermissions,
AccessBasedEnumeration, ShareComment }
    il8nstr PathName
    il8nstr ShareName
    str LanmanResName
    str MaxUsers
    str MountResName
    il8nstr UserPermissions{} = { Everyone=READ_ACCESS }
    boolean HiddenShare = 0
    boolean ShareSubdirectories = 0
    boolean HideChildShares = 0
    boolean AutoShare = 1
    boolean AutoControl = 1
    str ClientCacheType = MANUAL
    boolean IgnorePermissions = 0
    boolean AccessBasedEnumeration = 0
    str ShareComment
)
```

Attribute definitions

Table 4-1 FileShare agent required attributes

Required Attributes	Type and Dimension	Description
LanmanResName	string-scalar	<p>The name of the Lanman resource on which the FileShare resource depends.</p> <p>If this attribute is not specified, the agent behavior is as follows:</p> <ul style="list-style-type: none">■ On Windows Server 2008, the FileShare resource faults.
MountResName	string-scalar	<p>The name of the MountV resource on which the FileShare resource depends.</p> <p>For NetApp storage, this is the NetAppSnapDrive resource name.</p> <p>In case of Logical Disk Management, this is the Mount resource name.</p>
PathName	string-scalar	<p>The path of the folder to be shared.</p> <p>To share a drive, specify the PathName as \.</p> <p>For example, to share drive X:, the PathName is \.</p> <p>To share a folder on a mounted drive, specify the PathName as <i>\directoryname</i>.</p> <p>Note: This attribute can take localized values.</p>
ShareName	string-scalar	<p>The name by which the share is known to clients.</p> <p>Note: This attribute can take localized values.</p>

Table 4-2 FileShare agent optional attributes

Optional Attributes	Type and Dimension	Description
AutoControl	boolean-scalar	<p>Defines the agent behavior when share properties are modified (either within or from outside VCS) when the FileShare resource is online.</p> <p>The value 1 indicates that the agent synchronizes the changes made to the share properties with those that were defined while configuring the file share service group in the cluster.</p> <p>The value 0 indicates that the agent does not synchronize the share properties as per what is defined in the cluster configuration.</p> <p>If this attribute is set to 0 and the share properties are modified (either within or from outside VCS), the FileShare resource goes into the UNKNOWN state. The changes made to the share properties remain in effect until the resource is in the UNKNOWN state.</p> <p>To restore the state, you have to take the FileShare resource offline and bring it online again. When the resource is brought online, the agent restores the share properties as per what is defined in the cluster configuration.</p> <p>Default is 1.</p> <p>To make an existing share highly available, the share name and the share permissions in the configuration file must be the same as those for the file share.</p>

Table 4-2 FileShare agent optional attributes (Continued)

Optional Attributes	Type and Dimension	Description
AutoShare	boolean-scalar	<p>Defines agent behavior when a folder with shared subfolders is added to a VCS file share. The value 1 indicates the agent automatically shares the newly added subfolder in its next monitor cycle. The value 0 indicates the agent does not.</p> <p>Default is 1.</p> <p>This attribute is considered only if the attribute ShareSubdirectories is set to 1.</p>

Table 4-2 FileShare agent optional attributes (Continued)

Optional Attributes	Type and Dimension	Description
ClientCacheType	string-scalar	<p>A string that specifies whether the files and programs in the shared folder are cached locally on the client computer when accessed by users. It also specifies how the files are cached. The cached files are then available offline even if users are not connected to the share.</p> <p>Note: The agent does not cache the files or programs itself. It sets the value so that the server and client interfaces do the needful.</p> <p>This attribute can have the following values:</p> <ul style="list-style-type: none">■ MANUAL: Indicates that only the files and programs specified by the users are cached.■ NONE: Indicates that files and programs from the share are not cached.■ DOCS: Indicates that all the files and programs that the users open from the share are automatically cached. Files and programs that are not opened are not available offline.■ PROGRAMS: Indicates that all files and programs that the users open from the share are automatically cached and are optimized for performance. The next time the user accesses the executable files, they are launched from the local cache. Files and programs that are not accessed are not available offline. <p>Default is MANUAL.</p>

Table 4-2 FileShare agent optional attributes (Continued)

Optional Attributes	Type and Dimension	Description
HiddenShare	boolean-scalar	<p>Defines whether the agent hides the file share. The value 1 indicates the agent hides the file share. The value 0 indicates it does not.</p> <p>Default is 0.</p> <p>Note: To create a hidden share, set the HiddenShare attribute to 1. Do not append the share name with a \$ (dollar) sign.</p>
HideChildShares	boolean-scalar	<p>Defines whether the agent hides the subfolder shares. The value 1 indicates the agent hides the subfolder shares. The value 0 indicates it does not.</p> <p>Default is 0.</p> <p>This attribute is considered only if the attribute ShareSubdirectories is set to 1.</p>
IgnorePermissions	boolean-scalar	<p>This attribute has been deprecated.</p> <p>Please use AutoControl attribute instead.</p>
MaxUsers	string-scalar	<p>The maximum number of users that can access the file share. Default is null, which indicates access is granted to maximum users allowed on Windows.</p> <p>If this attribute is set to zero or greater than the maximum users allowed on Windows, access is granted to the maximum users allowed on Windows.</p>

Table 4-2 FileShare agent optional attributes (Continued)

Optional Attributes	Type and Dimension	Description
ShareSubdirectories	boolean-scalar	<p>Defines whether the agent shares the subfolders of the file shares defined in the attribute PathName and ShareName. Subfolders are shared with their own names, that is, the share name of a subfolder is the same as the subfolder name. If a share with the same name exists, the subfolder will not be shared. However, this does not affect the state of the resource.</p> <p>The value 1 indicates the agent shares the subfolders. The value 0 indicates it does not.</p> <p>Default is 0.</p> <p>Note: Sharing a folder with a large number of subfolders and enabling the ShareSubdirectories attribute may cause increased failover time and high CPU and memory utilization.</p>

Table 4-2 FileShare agent optional attributes (Continued)

Optional Attributes	Type and Dimension	Description
UserPermissions	string-association	<p>The permissions with which the folders are shared for users.</p> <p>The following permissions are associated with the FileShare resource:</p> <ul style="list-style-type: none"> ■ FULL_CONTROL: Permission to read, write, create, execute, and delete the resource, and to modify its attributes and permissions. ■ READ_ACCESS: Permission to read, and execute the resource. ■ CHANGE_ACCESS: Permission to read, write, execute, and delete the resource. ■ NO_ACCESS: No access to the resource. <p>The UserPermissions are specified in the format <i>'Domain_Name\Username'=Permission.</i></p> <p>For example, to give full control to user John who belongs to the domain vcs_domain, the syntax is <i>'VCS_DOMAIN\John'=FULL_CONTROL.</i></p> <p>The domain name and the user name must be enclosed in quotation marks.</p> <p>Default is {'Everyone' = READ_ACCESS}.</p> <p>A maximum of 50 users can be configured for each file share. To configure more than 50 users for a file share, configure user groups.</p> <p>Note that the agent monitors only the users and the permissions that are defined in the VCS configuration.</p> <p>Note: This attribute can take localized values.</p>

Table 4-2 FileShare agent optional attributes (Continued)

Optional Attributes	Type and Dimension	Description
AccessBasedEnumeration	boolean-scalar	Defines whether the agent enables the Windows Access-based Enumeration option for the specified file share. The value 1 indicates that the agent enables it and the value 0 indicates that the agent does not. Default is 0.
ShareComment	string-scalar	A string that describes the share. Use this attribute to add comments to the file share resource. If this attribute is blank, the agent uses the default VCS comment.

Sample configuration

Sample file share configuration using the SFW agents (MountV/VMDg):

```
FileShare FileShare_SG-FileShare (
    PathName = "\\ToShare"
    ShareName = ToShare
    LanmanResName = FileShare_SG-Lanman
    MaxUsers = 100
    MountResName = FileShare_SG-MountV
    UserPermissions = { "VCSNET\\Administrator" = READ_ACCESS }
    ShareSubdirectories = 1
    HideChildShares = 1
    AccessBasedEnumeration = 1
)

IP FileShare_SG-IP (
    Address = "10.212.100.184"
    SubNetMask = "255.255.254.0"
    MACAddress @SYSTEM1 = "00-02-B3-AD-CE-E4"
    MACAddress @SYSTEM2 = "00-02-B3-AD-CB-D0"
)

Lanman FileShare_SG-Lanman (
    VirtualName = VNAME
    IPResName = FileShare_SG-IP
)

MountV FileShare_SG-MountV (
    MountPath = "J:"
    VolumeName = PS-SPOOL
```

```
VMDGResName = FileShare_SG-VMDg
)

NIC FileShare_SG-NIC (
  MACAddress @SYSTEM1 = "00-02-B3-AD-CE-E4"
  MACAddress @SYSTEM2 = "00-02-B3-AD-CB-D0"
)

VMDg FileShare_SG-VMDg (
  DiskGroupName = PRINTSHARE_DG
  DGGuid = e40b8ab5-88ac-42e3-ae61-cbea3a164af2
)

FileShare_SG-Lanman requires FileShare_SG-IP
FileShare_SG-MountV requires FileShare_SG-VMDg
FileShare_SG-FileShare requires FileShare_SG-Lanman
FileShare_SG-FileShare requires FileShare_SG-MountV
FileShare_SG-IP requires FileShare_SG-NIC
```

CompositeFileShare agent

The CompositeFileShare agent enables systems to share multiple subfolders for each of the shared folders. The folders to be shared are stored on shared disks. Using the CompositeFileShare agent you can also do the following:

- Create hidden shares for shared folders or subfolders.
- Dynamically share the subfolders created after the resource is brought online.
- Configure and control existing shares.

The CompositeFileShare agent enables sharing folders shared outside VCS. However, you cannot add special shares (those created by the operating system for administrative and system use) to the VCS configuration. For example, you cannot add the shares ADMIN\$, print\$, IPC\$, and *DriveLetter\$*.

The agent simplifies the process of configuring multiple file shares. It defines file shares in an array, thereby eliminating the need to specify dependencies for each FileShare resource. Each CompositeFileShare resource can be configured for a maximum of 50 file shares.

For information on configuring a composite file share service group, refer to the *Veritas Cluster Server Administrator's Guide*.

Dependencies

The CompositeFileShare resource depends on the MountV resource. A CompositeFileShare service group also requires a Lanman resource that is dependent on the IP resource, as illustrated in the following dependency graph.

Figure 4-2 CompositeFileShare service group dependency graph

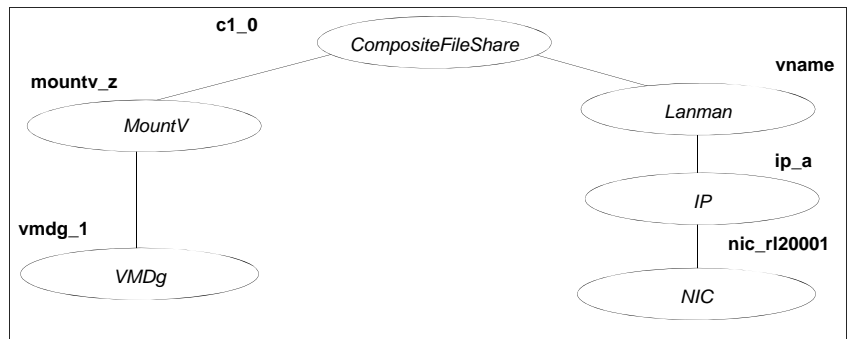

Note: In case of a NetApp storage environment, use the NetApp Filer and NetApp SnapDrive agents instead of the VMDg and MountV agents respectively. If you are using Logical Disk Management (LDM) for configuring your storage, use the Mount and the DiskRes agents.

Agent functions

Online	Shares the specified folders with designated permissions.
Offline	Removes the shares for the specified folders.
Monitor	Verifies at least one specified folder is shared with the designated permissions.

State definitions

ONLINE	Indicates at least one specified folder is shared.
OFFLINE	Indicates no specified folder is shared.
UNKNOWN	Indicates the agent could not determine the status of the resource.

Note: Sharing a folder with a large number of subfolders and enabling the ShareSubdirectories attribute may cause increased failover time and high CPU and memory utilization.

About ForceControl function

ForceControl is a FileShare agent function that allows you to reset the file share properties as per what is defined in the VCS configuration. The agent overwrites all modifications made to the file share properties, either externally or from within VCS, and sets the properties as per what you had defined while configuring the file shares in VCS. This function overrides the FileShare agent's AutoControl attribute settings.

You can run the ForceControl function from the command line. To run the ForceControl function on a fileshare resource, type the following command:

```
hares -action <fileshare_resource_name> ForceControl  
-sys <system_name>
```

Here, *<fileshare_resource_name>* is the name of the file share resource for which you want to reset the properties and *<system_name>* is the name of the cluster node on which that file share resource is online.

For example, to run the ForceControl function on a FileShare resource *A_fileshare* that is currently online on a cluster node *Node1*, type the following:

```
hares -action A_fileshare ForceControl -sys Node1
```

The changes take effect on the next agent monitor function.

Resource type definition

```
type CompositeFileShare
static keylist SupportedActions = { ForceControl }
static il8nstr ArgList[] = { "LanmanResName:VirtualName", MaxUsers,
"MountResName:MountPath", HiddenShare, ShareSubdirectories,
HideChildShares, AutoShare, AutoControl, ClientCacheType,
PathAndShareName, UserPermissions, AccessBasedEnumeration,
ShareComment }
    str LanmanResName
    str MaxUsers
    str MountResName
    il8nstr UserPermissions{} = { Everyone=READ_ACCESS }
    boolean HiddenShare = 0
    boolean ShareSubdirectories = 0
    boolean HideChildShares = 0
    boolean AutoShare = 1
    boolean AutoControl = 1
    il8nstr PathAndShareName{}
    str ClientCacheType = MANUAL
    boolean IgnorePermissions = 0
    boolean AccessBasedEnumeration = 0
    str ShareComment
)
```

Attribute definitions

Table 4-3 CompositeFileShare agent required attributes

Required Attributes	Type and Dimension	Description
LanmanResName	string-scalar	<p>The name of the Lanman resource on which the CompositeFileShare resource depends.</p> <p>If this attribute is not specified, the agent behavior is as follows:</p> <ul style="list-style-type: none"> ■ On Windows Server 2008, the FileShare resource faults.
MountResName	string-scalar	<p>The name of the MountV resource on which the CompositeFileShare resource depends.</p> <p>For NetApp storage, this is the NetAppSnapDrive resource name.</p> <p>In case of Logical Disk Management, this is the Mount resource name.</p>
PathandShareName	string-association	<p>A list specifying the respective paths and share names of the folders to be shared. If the path of a shared folder is \Documents, and the share name is UserDocs, the attribute value is defined in the configuration file as</p> <pre>{"\Documents" = "UserDocs"}.</pre> <p>While editing the attribute from the Cluster Manager (Java Console) or the command line, specify a single slash for the shared folder. While editing the configuration file main.cf directly, specify two slashes (\\); for example, \\Documents.</p> <p>Note: This attribute can take localized values.</p>

Table 4-4 CompositeFileShare agent optional attributes

Optional Attributes	Type and Dimension	Description
AutoControl	boolean-scalar	<p>Defines the agent behavior when share properties are modified (either within or from outside VCS) when the FileShare resource is online.</p> <p>The value 1 indicates that the agent synchronizes the changes made to the share properties with those that were defined while configuring the file share service group in the cluster.</p> <p>The value 0 indicates that the agent does not synchronize the share properties as per what is defined in the cluster configuration.</p> <p>If this attribute is set to 0 and the share properties are modified (either within or from outside VCS), the FileShare resource goes into the UNKNOWN state. The changes made to the share properties remain in effect until the resource is in the UNKNOWN state.</p> <p>To restore the state, you have to take the CompositeFileShare resource offline and bring it online again. When the resource is brought online, the agent restores the share properties as per what is defined in the cluster configuration.</p> <p>Default is 1.</p> <p>To make an existing share highly available, the share name and the share permissions in the configuration file must be the same as those for the file share.</p>

Table 4-4 CompositeFileShare agent optional attributes (Continued)

Optional Attributes	Type and Dimension	Description
AutoShare	boolean-scalar	<p>Defines agent behavior when a folder is added to a VCS file share with shared subfolders. The value 1 indicates the agent automatically shares the newly added subfolder in its next monitor cycle. The value 0 indicates the agent does not.</p> <p>Default is 1.</p> <p>This attribute is considered only if the attribute ShareSubdirectories is set to 1.</p>

Table 4-4 CompositeFileShare agent optional attributes (Continued)

Optional Attributes	Type and Dimension	Description
ClientCacheType	string-scalar	<p>A string that specifies whether the files and programs in the shared folder are cached locally on the client computer when accessed by users. It also specifies how the files are cached. The cached files are then available offline even if users are not connected to the share.</p> <p>Note: The agent does not cache the files or programs itself. It sets the value so that the server and client interfaces do the needful.</p> <p>This attribute can have the following values:</p> <ul style="list-style-type: none">■ MANUAL: Indicates that only the files and programs specified by the users are cached.■ NONE: Indicates that files and programs from the share are not cached.■ DOCS: Indicates that all the files and programs that the users open from the share are automatically cached. Files and programs that are not opened are not available offline.■ PROGRAMS: Indicates that all the files and programs that the users open from the share are automatically cached and are optimized for performance. Files and programs that are not opened are not available offline. <p>Default is MANUAL.</p>

Table 4-4 CompositeFileShare agent optional attributes (Continued)

Optional Attributes	Type and Dimension	Description
HiddenShare	boolean-scalar	<p>Defines whether the agent hides the file share. The value 1 indicates the agent hides the file share. The value 0 indicates it does not.</p> <p>Default is 0.</p> <p>Note: To create a hidden share, set the HiddenShare attribute to 1. Do not append the share name with a \$ (dollar) sign.</p>
HideChildShares	boolean-scalar	<p>Defines whether the agent hides the subfolder shares. The value 1 indicates the agent hides the subfolder shares. The value 0 indicates it does not.</p> <p>Default is 0.</p> <p>This attribute is considered only if the attribute ShareSubdirectories is set to 1.</p>
IgnorePermissions	boolean-scalar	<p>This attribute has been deprecated.</p> <p>Please use AutoControl attribute instead.</p>
MaxUsers	string-scalar	<p>The maximum number of users that can access the file share. Default is null, which indicates access is granted to maximum users allowed on Windows.</p> <p>If this attribute is set to zero or greater than the maximum users allowed on Windows, access is granted to the maximum users allowed on Windows.</p>

Table 4-4 CompositeFileShare agent optional attributes (Continued)

Optional Attributes	Type and Dimension	Description
ShareSubdirectories	boolean-scalar	<p>Defines whether the agent shares the subfolders of the file shares defined in the attribute PathAndShareName. Subfolders are shared with their own names, that is, the share name of a subfolder is the same as the subfolder name. If a share with the same name exists, the subfolder will not be shared. However, this does not affect the state of the resource.</p> <p>The value 1 indicates the agent shares the subfolders. The value 0 indicates it does not.</p> <p>Default is 0.</p> <p>Note: Sharing a folder with a large number of subfolders and enabling the ShareSubdirectories attribute may cause increased failover time and high CPU and memory utilization.</p>

Table 4-4 CompositeFileShare agent optional attributes (Continued)

Optional Attributes	Type and Dimension	Description
UserPermissions	string-association	<p>The permissions with which the folders are shared for users. The user permissions do not apply to individual file shares. User permissions apply to all file shares that form the CompositeFileShare resource.</p> <p>The following permissions are associated with the CompositeFileShare resource:</p> <ul style="list-style-type: none"> ■ FULL_CONTROL: Permission to read, write, create, execute, and delete the resource, and to modify its attributes and permissions. ■ READ_ACCESS: Permission to read, and execute the resource. ■ CHANGE_ACCESS: Permission to read, write, execute, and delete the resource. ■ NO_ACCESS: No access to the resource. <p>The UserPermissions are specified in the format <i>'Domain_Name\Username'=Permission</i>.</p> <p>For example, to give full control to user John who belongs to the domain vcs_domain, the syntax is <i>'VCS_DOMAIN\John'=FULL_CONTROL</i></p> <p>The domain name and the user name must be enclosed in quotation marks.</p> <p>Default is {'Everyone' = READ_ACCESS}.</p> <p>A maximum of 50 users can be configured for each file share. To configure more than 50 users for a file share, configure user groups.</p> <p>Note that the agent monitors only the users and the permissions that are defined in the VCS configuration.</p> <p>Note: This attribute can take localized values.</p>

Table 4-4 CompositeFileShare agent optional attributes (Continued)

Optional Attributes	Type and Dimension	Description
AccessBasedEnumeration	boolean-scalar	Defines whether the agent enables the Windows Access-based Enumeration option for the specified file share. The value 1 indicates that the agent enables it and the value 0 indicates that the agent does not. Default is 0.
ShareComment	string-scalar	A string that describes the share. Use this attribute to add comments to the compositefileshare resource. If this attribute is blank, the agent uses the default VCS comment.

Sample configuration

```
CompositeCFS CFS-RES (
  Critical = 1
  LanmanResName = CFS_SG-Lanman
  MountResName = CFS_SG-MountV
  UserPermissions = { Everyone = READ_ONLY }
  ShareSubdirectories = 1
  PathAndShareName = { "\\share2" = share2,
  "\\share3" = share3 }
  AccessBasedEnumeration = 1
)

IP CFS_SG-IP (
  Address = "10.212.100.184"
  SubNetMask = "255.255.254.0"
  MACAddress @SYSTEM1 = "00-02-B3-AD-CE-E4"
  MACAddress @SYSTEM2 = "00-02-B3-AD-CB-D0"
)

Lanman CFS_SG-Lanman (
  VirtualName = VNAME
  IPResName = CFS_SG-IP
)

MountV CFS_SG-MountV (
  MountPath = "J:"
  VolumeName = PS-SPOOL
  VMDGResName = CFS_SG-VMDg
)

NIC CFS_SG-NIC (
  MACAddress @SYSTEM1 = "00-02-B3-AD-CE-E4"
  MACAddress @SYSTEM2 = "00-02-B3-AD-CB-D0"
)

VMDg CFS_SG-VMDg (
  DiskGroupName = PRINTSHARE_DG
  DGGuid = e40b8ab5-88ac-42e3-ae61-cbea3a164af2
)

CFS_SG-Lanman requires CFS_SG-IP
CFS_SG-MountV requires CFS_SG-VMDg
CFS-RES requires CFS_SG-Lanman
CFS-RES requires CFS_SG-MountV
CFS_SG-IP requires CFS_SG-NIC
```

PrintShare agents

This chapter contains the following topics:

- [“About PrintShare agents”](#) on page 98
- [“PrintSpool agent”](#) on page 98
- [“PrintShare agent”](#) on page 102

About PrintShare agents

The PrintShare agents work together to make a shared network printer highly available. The PrintSpool agent provides high availability for a print spooler and the PrintShare agent makes a network printer highly available.

PrintSpool agent

The PrintSpool agent makes a print spooler highly available and binds it to the virtual computer. It ensures that spooling does not occur locally. The agent is used in conjunction with the PrintShare agent to make a print server highly available. You can configure only one PrintSpool resource for one virtual computer.

Dependencies

The PrintSpool resource depends on the MountV and Lanman resources for operation. It also requires the Print Spooler service configured as a ServiceMonitor resource.

The following figure illustrates the PrintSpool agent's dependency graph:

Figure 5-1 PrintSpool service group dependency graph

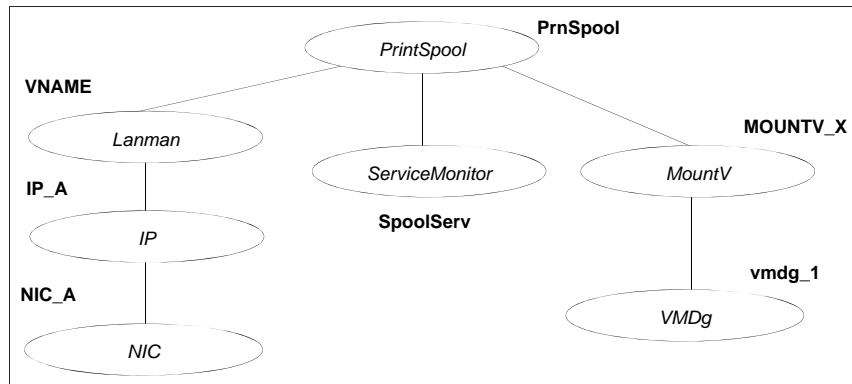

Note: In case of a NetApp storage environment, the NetApp Filer and NetApp SnapDrive agents are used instead of the VMDg and MountV agents respectively.

Agent functions

- **online**—Creates a virtual spooler and binds it with the virtual computer. The agent also loads the printspool registry hive.
- **offline**—Stops the virtual spooler and unloads the printspool registry hive.
- **monitor**—Verifies the spooler is bound to the virtual computer.

State definitions

- **ONLINE**—Indicates the virtual spooler is active on the virtual computer.
- **OFFLINE**—Indicates the virtual spooler is not active on the virtual computer.
- **UNKNOWN**—Indicates the agent could not determine the status of the virtual spooler.

Resource type definition

```

type PrintSpool (
    static i18nstr ArgList[] = {"LanmanResName:VirtualName",
    "IPResName:Address", "MountResName:MountPath", SpoolDir,
    "RegMountResName:MountPath", RegDir}
    str LanmanResName
    str IPResName
    str MountResName
    i18nstr SpoolDir
    str RegMountResName
    i18nstr RegDir
)
    
```

Attribute definitions

Table 5-1 PrintSpool agent required attributes

Required Attributes	Type and Dimension	Description
IPResName	string-scalar	The name of the IP resource on which the Lanman resource specified by the attribute LanmanResName depends.
LanmanResName	string-scalar	The name of the Lanman resource on which the PrintSpool resource depends. The print spooler is bound to the virtual computer associated with this Lanman resource.

Table 5-1 PrintSpool agent required attributes

Required Attributes	Type and Dimension	Description
MountResName	string-scalar	The name of the MountV resource on which the PrintSpool resource depends. This resource must point to the drive on the shared disk where the spool directory will reside. In case of a NetApp storage environment, this will be the name of the NetAppSnapDrive resource.
SpoolDir	string-scalar	A directory on the shared disk to be used for spooling. The value for SpoolDir attribute must be relative to the drive letter for MountResName. Note: This attribute can take localized values.
RegMountResName	string-scalar	The name of the MountV resource on which the PrintSpool resource depends. This resource must point to the drive on the shared disk where the regrep directory will reside. You can configure only one MountV resource for both spooler and regrep; in that case the value of this attribute will be the same as that of the MountResName attribute. In case of a NetApp storage environment, this will be the name of the NetAppSnapDrive resource.
RegDir	string-scalar	A directory on the shared disk that will be used by the virtual spooler to store the registry information. The value for RegDir attribute must be relative to the drive letter for RegMountResName.

Sample configuration

The following sample configuration creates a PrintSpool resource with the required Lanman, MountV, Service Monitor, and Registry Replication resources.

```
IP IP-10-212-100-184 (
  Address = "10.212.100.184"
  SubNetMask = "255.255.254.0"
  MACAddress @SYSTEM1 = "00-02-B3-AD-CB-D0"
  MACAddress @SYSTEM2 = "00-02-B3-AD-CE-E4"
)
```

```
Lanman Lanman-PRINTSHAREMAN (  
    VirtualName = PRINTSHAREMAN  
    IPResName = IP-10-212-100-184  
    ADCriticalForOnline = 1  
)  
  
MountV MountV-JDrive (  
    MountPath = "J:"  
    VolumeName = PS-SPOOL  
    VMDGResName = VMDg-PRINTSHARE_DG  
)  
  
MountV MountV-IDrive (  
    MountPath = "I:"  
    VolumeName = PS-REGREP  
    VMDGResName = VMDg-PRINTSHARE_DG  
)  
  
NIC NIC-PRINSHARE-SG (  
    MACAddress @SYSTEM1 = "00-02-B3-AD-CB-D0"  
    MACAddress @SYSTEM2 = "00-02-B3-AD-CE-E4"  
)  
  
PrintSpool PSSpool (  
    LanmanResName = Lanman-PRINTSHAREMAN  
    IPResName = IP-10-212-100-184  
    MountResName = MountV-JDrive  
    SpoolDir = "\\SPOOLER"  
    RegMountResName = MountV-IDrive  
    RegDir = "\\REGREP"  
)  
  
ServiceMonitor ServiceMonitor-PrintSpooler (  
    ServiceOrScriptName = "Print Spooler"  
)  
  
VMDg VMDg-PRINTSHARE_DG (  
    DiskGroupName = PRINTSHARE_DG  
)  
  
IP-10-212-100-184 requires NIC-PRINSHARE-SG  
Lanman-PRINTSHAREMAN requires IP-10-212-100-184  
MountV-JDrive requires VMDg-PRINTSHARE_DG  
MountV-IDrive requires VMDg-PRINTSHARE_DG  
PSSpool requires Lanman-PRINTSHAREMAN  
PSSpool requires MountV-JDrive  
PSSpool requires MountV-IDrive  
PSSpool requires ServiceMonitor-PrintSpooler
```

PrintShare agent

The PrintShare agent enables systems to share a network printer from a cluster so that the clients can access it. The agent adds, monitors, and removes a share to the network printer from the virtual computer. Configure a PrintShare service group using the PrintShare configuration wizard, described in the *Veritas Cluster Server Administrator's Guide*.

Dependency

The PrintShare resource depends on the PrintSpool resource.

Agent functions

- **online**—Adds a share to the network printer on the virtual computer.
- **offline**—Deletes the share to the network printer from the virtual computer.
- **monitor**—Verifies that the share to the network printer exists.

State definitions

- **ONLINE**—Indicates the network printer is shared from the virtual computer.
- **OFFLINE**—Indicates the network printer is not shared from the virtual computer.
- **UNKNOWN**—Indicates the agent could not determine the status of the resource.

Resource type definition

```
type PrintShare (  
    static i18nstr ArgList[] = {PrinterName, ShareName,  
        "LanmanResName:VirtualName" }  
    i18nstr PrinterName  
    i18nstr ShareName  
    str LanmanResName  
)
```

Attribute definitions

Table 5-2 PrintShare agent required attributes

Required Attributes	Type and Dimension	Description
LanmanResName	string-scalar	The name of the Lanman resource configured for the virtual computer.
PrinterName	string-scalar	The name of the network printer to be shared. This attribute can take localized values.
ShareName	string-scalar	The name by which the network printer will be shared. This attribute can take localized values.

Sample configuration

The following sample configuration creates a PrintShare resource with the required PrintSpool and ServiceMonitor resources.

```
IP IP-10-212-100-184 (  
  Address = "10.212.100.184"  
  SubNetMask = "255.255.254.0"  
  MACAddress @SYSTEM1 = "00-02-B3-AD-CB-D0"  
  MACAddress @SYSTEM2 = "00-02-B3-AD-CE-E4"  
)  
  
Lanman Lanman-PRINTSHAREMAN (  
  VirtualName = PRINTSHAREMAN  
  IPResName = IP-10-212-100-184  
  ADCriticalForOnline = 1  
)  
  
MountV MountV-JDrive (  
  MountPath = "J:"  
  VolumeName = PS-SPOOL  
  VMDGResName = VMDg-PRINTSHARE_DG  
)  
  
MountV MountV-IDrive (  
  MountPath = "I:"  
  VolumeName = PS-REGREP  
  VMDGResName = VMDg-PRINTSHARE_DG  
)  
  
NIC NIC-PRINSHARE-SG (  
  MACAddress @SYSTEM1 = "00-02-B3-AD-CB-D0"  
  MACAddress @SYSTEM2 = "00-02-B3-AD-CE-E4"  
)
```

```
PrintShare PSSHare (  
    PrinterName = "HP LaserJet 4050 Series PCL"  
    ShareName = "HP LaserJet 4050 Series PCL"  
    LanmanResName = Lanman-PRINTSHAREMAN  
)
```

```
PrintSpool PSSpool (  
    LanmanResName = Lanman-PRINTSHAREMAN  
    IPResName = IP-10-212-100-184  
    MountResName = MountV-JDrive  
    SpoolDir = "\\SPOOLER"  
    RegMountResName = MountV-IDrive  
    RegDir = "\\REGREP"  
)
```

```
ServiceMonitor ServiceMonitor-PrintSpooler (  
    ServiceOrScriptName = "Print Spooler"  
)
```

```
VMDg VMDg-PRINTSHARE_DG (  
    DiskGroupName = PRINTSHARE_DG  
)
```

```
IP-10-212-100-184 requires NIC-PRINSHARE-SG  
Lanman-PRINTSHAREMAN requires IP-10-212-100-184  
MountV-JDrive requires VMDg-PRINTSHARE_DG  
MountV-IDrive requires VMDg-PRINTSHARE_DG  
PSSHare requires PSSpool  
PSSpool requires Lanman-PRINTSHAREMAN  
PSSpool requires MountV-JDrive  
PSSpool requires MountV-IDrive  
PSSpool requires ServiceMonitor-PrintSpooler  
VNAME requires IP_A
```

Services and applications agents

This chapter contains the following topics:

- [“About services and application agents”](#) on page 106
- [“Internet Information Services \(IIS\) agent”](#) on page 107
- [“GenericService agent”](#) on page 115
- [“ServiceMonitor agent”](#) on page 119
- [“Process agent”](#) on page 125
- [“MSMQ agent”](#) on page 132

About services and application agents

Services and applications agents make generic services and other applications highly available.

- The Internet Information Services (IIS) agent brings IIS sites and services online, monitors their status, and takes them offline.
- The GenericService agent brings services online, monitors their status, and takes them offline.
- The ServiceMonitor agent only monitors a service or starts a user-defined script and interprets the exit code of the script.
- The Process agent brings processes online, monitors their status, and takes them offline.
- The MSMQ agent works with the Microsoft Message Queuing (MSMQ) service. The MSMQ agent creates an MSMQ service for an MSMQ resource, brings the MSMQ service online, takes it offline, and monitors its status.

Internet Information Services (IIS) agent

The Internet Information Services (IIS) agent provides high availability to sites configured using Microsoft IIS. Specifically, the agent brings IIS sites online, monitors their status, and takes them offline.

The agent provides two ways of monitoring application pools associated with IIS Web sites:

- One IIS resource configures a Web site and sets monitoring options for application pools associated with the site.
- One IIS resource configures a Web site; other resources configure individual application pools.

The IIS agent supports intelligent resource monitoring and uses Intelligent Monitoring Framework (IMF) for resource state change notifications. IMF-based monitoring support is limited only to monitoring the IIS services (FTP service, World Wide Web Publishing Service) that are necessary for the functioning of IIS. The agent traps the Windows service related events and takes appropriate action if a configured service stops or fails to respond. IMF is not used for monitoring the availability of the sites configured.

For more information about IMF, refer to the *Veritas Cluster Server Administrator's Guide*.

Note: The IIS agent does not support IPv6 for IIS 6.0 or earlier versions.

Agent functions

- **online**—Starts the configured site or application pool.
- **offline**—Stops the configured site or application pool.
- **monitor**—Verifies the configured site or application pool is running.

State definitions

- **ONLINE**—Indicates the configured site or application pool is available.
- **OFFLINE**—Indicates the configured site or application pool is not available.
- **UNKNOWN**—Indicates the agent could not determine the status of the resource.

Resource type definition

```
type IIS (
```

```

static il8nstr ArgList[] = {SiteType, SiteName,
  "IPResName:Address", PortNumber, AppPoolMon, DetailMonitor,
  DetailMonitorInterval }
str SiteType
il8nstr SiteName
int PortNumber = 80
str AppPoolMon = NONE
boolean DetailMonitor = 0
int DetailMonitorInterval = 5
str IPResName
)

```

Attribute definitions

To configure the agent to monitor an application pool, configure the SiteType and SiteName attributes only. The agent ignores other attributes when it is configured to monitor an application pool.

Table 6-1 IIS agent required attributes

Required Attributes	Type and Dimension	Description
SiteType	string-scalar	<p>Defines whether the resource is configured to monitor an IIS site or an application pool.</p> <p>If the resource is configured to monitor an application pool, set the attribute to APPPOOL.</p> <p>If the resource is configured to monitor an IIS site, set this attribute to the name of the IIS service associated with the site. The attribute can take any of the following values:</p> <ul style="list-style-type: none"> ■ W3SVC ■ MSFTPSVC ■ SMTPSVC ■ NNTPSVC

Table 6-1 IIS agent required attributes

Required Attributes	Type and Dimension	Description
SiteName	string-scalar	<p>The name of the IIS site, the virtual server, or the application pool to be monitored by the agent.</p> <p>The value of this attribute depends on that of the SiteType attribute. The SiteName attribute can take the following values:</p> <ul style="list-style-type: none"> ■ The name of a site, if SiteType is W3SVC or MSFTPSVC ■ The name of a virtual server, if SiteType is SMTPSVC or NNTPSVC ■ The name of an application pool, if SiteType is APPPOOL <p>Note: This attribute can take localized values.</p>
IPResName	string-scalar	The name of the IP resource configured for the IP to which the site is bound.
PortNumber	string-scalar	The port to which the site is bound.

Table 6-2 IIS agent optional attributes

Optional Attributes	Type and Dimension	Description
AppPoolMon	integer-scalar	<p>Defines the monitoring modes for the application pool associated with the Web site being monitored.</p> <p>Configure this attribute only if SiteType is W3SVC and IIS is configured to run in the Worker Process Isolation mode.</p> <p>The attribute can take one of the following values:</p> <ul style="list-style-type: none"> ■ NONE: Indicates that the agent will not monitor the application pool associated with the Web site. ■ DEFAULT: Indicates that the agent will monitor the <i>root</i> application pool associated with the Web site. If this attribute is set, the agent starts, stops, and monitors the root application pool associated with the Web site. If the root application pool is stopped externally, the agent fails over the service group. ■ ALL: Indicates the agent will start all application pools associated with the Web site, but will monitor and stop the <i>root</i> application pool only.
DetailMonitor	boolean-scalar	<p>Defines whether the agent monitors the site in detail. The value 1 indicates the agent will monitor each site in detail by attempting an actual socket connection to the port.</p>
DetailMonitorInterval	integer-scalar	<p>The number of monitor cycles after which the agent attempts detail monitoring. For example, the value 5 indicates that the agent will monitor the resource in detail after every 5 monitor cycles.</p>

Sample configurations

This section describes two sample configurations. The first configuration depicts how you can configure one IIS resource monitors a Web site and its associated application pools. The second configuration depicts how you can configure separate IIS resources to monitor Web sites and application pools.

Sample configuration I

In the following configuration the IIS sites are located in a shared disk group, which is configured using the VMDg resource type.

Figure 6-1 IIS service group dependency graph

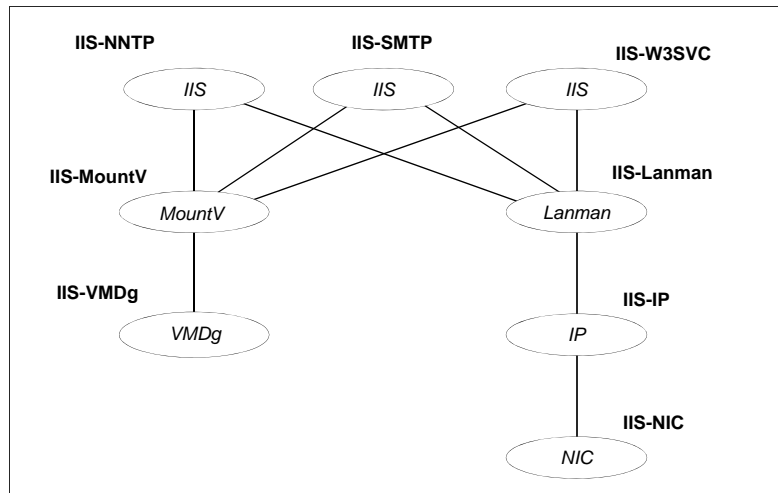

A MountV resource configures a drive letter for the shared disk group. The IIS sites share a virtual name and IP address, configured using the Lanman and IP resource types respectively. The IIS resources depend on the Lanman and MountV resources and can be started after these resources are brought online.

Note: In case of a NetApp storage environment, the NetApp Filer and NetApp SnapDrive agents are used instead of the VMDg and MountV agents respectively.

Sample main.cf file

```
IIS IIS-W3SVC (  
    SiteType = W3SVC  
    SiteName = "My Site"  
    AppPoolMon = DEFAULT  
    DetailMonitor = 1  
    IPResName = IIS-IP  
)  
  
IIS IIS-SMTP (  
    SiteType = SMTPSVC  
    SiteName = "Default SMTP Virtual Server"  
    PortNumber = 25  
    DetailMonitor = 1  
    IPResName = IIS-IP  
)  
  
IIS IIS-NNTP (  
    SiteType = NNTPSVC  
    SiteName = "Default NNTP Virtual Server"  
    PortNumber = 119  
    DetailMonitor = 1  
    IPResName = IIS-IP  
)  
  
IP IIS-IP (  
    Address = "10.182.145.223"  
    SubNetMask = "255.255.252.0"  
    MACAddress @SYSTEM1 = "00-50-04-1E-62-E0"  
    MACAddress @SYSTEM2 = "00-50-04-25-0E-C0"  
)  
  
Lanman IIS-Lanman (  
    VirtualName = VNAME  
    IPResName = IIS-IP  
)  
  
MountV IIS-MountV (  
    MountPath = "X:"  
    VolumeName = web  
    VMDGResName = IIS-VMDg  
    ForceUnmount = ALL  
)  
  
NIC IIS-NIC (  
    MACAddress @SYSTEM1 = "00-50-04-1E-62-E0"  
    MACAddress @SYSTEM2 = "00-50-04-25-0E-C0"  
)  
  
VMDg IIS-VMDg (  
    DiskGroupName = DG_1  
)  
  
IIS-W3SVC requires IIS-Lanman  
IIS-W3SVC requires IIS-MountV
```

IIS-SMTP requires IIS-Lanman
 IIS-SMTP requires IIS-MountV
 IIS-NNTP requires IIS-Lanman
 IIS-NNTP requires IIS-MountV
 IIS-IP requires IIS-NIC
 IIS-Lanman requires IIS-IP
 IIS-MountV requires IIS-VMDg

Sample configuration II

In the following configuration the IIS Web site is located in a shared disk group, which is configured using the VMDg resource type.

Figure 6-2 IIS service group dependency graph

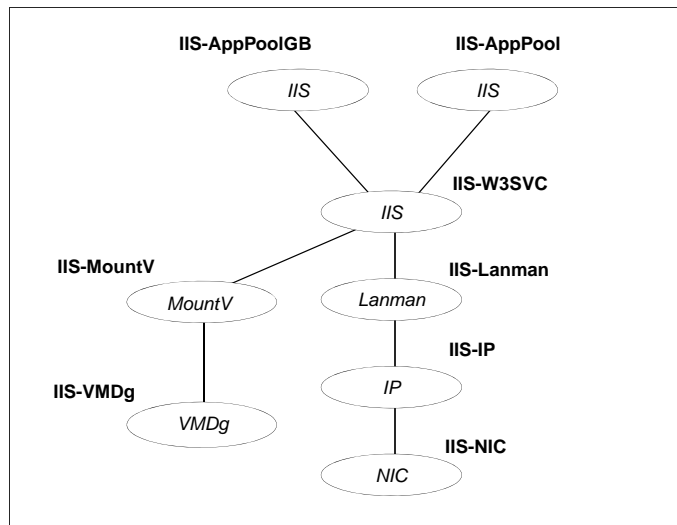

A MountV resource configures a drive letter for the shared disk group. The virtual name and IP address for the IIS resource are configured using the Lanman and IP resource types respectively. The application pools associated with the Web site are configured as separate resources of type IIS.

Note: In case of a NetApp storage environment, the NetApp Filer and NetApp SnapDrive agents are used instead of the VMDg and MountV agents respectively.

Sample main.cf file

```
IIS IIS-W3SVC (  
    SiteType = W3SVC  
    SiteName = "My Site"  
    AppPoolMon = DEFAULT  
    DetailMonitor = 1  
    IPResName = IIS-IP  
)  
  
IIS IIS-APPPPOOL (  
    SiteType = APPPOOL  
    SiteName = DefaultAppPool  
)  
  
IIS IIS-APPPPOOL_GB (  
    SiteType = APPPOOL  
    SiteName = GuestBook  
)  
  
IP IIS-IP (  
    Address = "10.182.145.223"  
    SubNetMask = "255.255.252.0"  
    MACAddress @SYSTEM1 = "00-50-04-1E-62-E0"  
    MACAddress @SYSTEM2 = "00-50-04-25-0E-C0"  
)  
  
Lanman IIS-Lanman (  
    VirtualName = VNAME  
    IPResName = IIS-IP  
)  
  
MountV IIS-MountV (  
    MountPath = "X:"  
    VolumeName = web  
    VMDGResName = IIS-VMDg  
    ForceUnmount = ALL  
)  
  
NIC IIS-NIC (  
    MACAddress @SYSTEM1 = "00-50-04-1E-62-E0"  
    MACAddress @SYSTEM2 = "00-50-04-25-0E-C0"  
)  
  
VMDg IIS-VMDg (  
    DiskGroupName = DG_1  
)  
IIS-W3SVC requires IIS-Lanman  
IIS-W3SVC requires IIS-MountV  
IIS-IP requires IIS-NIC  
IIS-Lanman requires IIS-IP  
IIS-MountV requires IIS-VMDg  
IIS-APPPPOOL requires IIS-W3SVC  
IIS-APPPPOOL_GB requires IIS-W3SVC
```

GenericService agent

The GenericService agent brings services online, takes them offline, and monitors their status. Note that a service is an application type supported by Windows that conforms to the interface rules of the Service Control Manager (SCM).

Services are defined as resources of type GenericService. You can configure the GenericService agent to monitor multiple services by defining a resource for each service to be monitored. You can monitor a service in a user-context by specifying the user name, password, and domain. You can start and monitor services in the virtual computer context by enabling the UseVirtualName attribute. Configure a service group for GenericService agent using the Application Configuration wizard, described in the *Veritas Cluster Server Administrator's Guide*.

The GenericService agent supports intelligent resource monitoring and uses Intelligent Monitoring Framework (IMF) for resource state change notifications. The agent traps the Windows service related events and takes appropriate action if a configured service stops or fails to respond. For more information about IMF, refer to the *Veritas Cluster Server Administrator's Guide*.

Note: The service to be configured using the GenericService agent must have the status as Stopped and the startup type as Manual.

Agent functions

- **online**—Starts the configured service.
- **offline**—Stops the configured service.
- **monitor**—Retrieves the current state of the configured service. It also verifies the user context, if applicable.

State definitions

- **ONLINE**—Indicates the service being monitored is online.
- **OFFLINE**—Indicates the service being monitored is offline.
- **UNKNOWN**—Indicates the service operation is in a pending state, or that the agent could not determine the state of the resource.

Resource type definition

```

type GenericService (
  static i18nstr ArgList[] = {ServiceName, DelayAfterOnline,
  DelayAfterOffline, UserAccount, Password, Domain, service_arg,
  UserVirtualName, "LanmanResName:VirtualName" }
  i18nstr ServiceName
  int DelayAfterOnline = 10
  int DelayAfterOffline = 10
  i18nstr UserAccount
  str Password
  i18nstr Domain
  str service_arg[]
  boolean UseVirtualName
  str LanmanResName
)

```

Attribute definitions

Table 6-3 GenericService agent required attributes

Required Attribute	Type and Dimension	Description
ServiceName	string-scalar	Name of the service to be monitored. The service name can be the Service Display Name or the Service Key Name. Note: This attribute can take localized values.

Table 6-4 GenericService agent optional attributes

Optional Attributes	Type and Dimension	Description
DelayAfterOffline	integer-scalar	Number of seconds the offline routine waits for the service to go offline. Modify this value depending on the time the configured service takes to stop once the resource is taken offline in the environment. Default is 10 seconds.

Table 6-4 GenericService agent optional attributes (Continued)

Optional Attributes	Type and Dimension	Description
DelayAfterOnline	integer-scalar	<p>Number of seconds the online routine waits for the service to go online.</p> <p>Modify this value depending on the time the configured service takes to start once the resource is taken online in the environment.</p> <p>Default is 10 seconds.</p>
Domain	string-scalar	<p>The domain to which the user specified in the UserAccount attribute belongs. If the domain name is not specified, the agent assumes that the user belongs to the local machine.</p> <p>This attribute is ignored if the UserAccount attribute is not specified or if the domain name is specified in the UserAccount attribute itself.</p> <p>Note: This attribute can take localized values.</p>
Password	string-scalar	<p>The password of the user, in whose context, the service would be started. If the UserAccount attribute is empty or contains a built-in service account, this attribute is ignored.</p>
service_arg	string-vector	<p>An array of arguments passed to the service.</p>
UserAccount	string-scalar	<p>A valid user account in whose context the service will be monitored. Username can be of the form username@domain.com or domain.com\username.</p> <p>If you do not specify a value for this attribute, then the user account of the service in the SCM is ignored.</p> <p>To monitor service under built-in accounts, you must provide explicit values. For example: UserAccount='LocalSystem', 'Local Service', or 'Network Service'. Domain='NT Authority'.</p> <p>The 'NT Authority' domain is not applicable for the 'LocalSystem' account.</p> <p>Note: This attribute can take localized values.</p>

Table 6-4 GenericService agent optional attributes (Continued)

Optional Attributes	Type and Dimension	Description
UseVirtualName	boolean-scalar	<p>Set this value to enable the service specified by the ServiceName attribute to inherit the Virtual Server context of Lanman resource specified in LanmanResName attribute. If this attribute is set, the LanmanResName becomes a mandatory attribute.</p> <p>Note: It is recommended that you do not set this attribute for system services. If you configure system services using the GenericService agent, then this attribute is not supported.</p>
LanmanResName	string-scalar	<p>The name of the Lanman resource on which the GenericService resource depends.</p> <p>Note: It is recommended that you do not set this attribute for system services. If you configure system services using the GenericService agent, then this attribute is not supported.</p>

Sample configuration

```
GenericService Telephony_Service (
    ServiceName = "Telephony Service"
    DelayAfterOnline = 10
    DelayAfterOffline = 10
    UserAccount = Administrator
    Password = bphNepE
    Domain = VCS-DOMAIN
    service_arg = { 3 }
)
```

ServiceMonitor agent

The ServiceMonitor agent monitors a service or starts a user-defined script and interprets the exit code of the script. A service is an application type supported by Windows that conforms to the interface rules of the SCM. The agent can be configured to monitor a service using the Service Control Manager (SCM) or through a user-defined script.

When configured to monitor using the SCM, the agent queries the SCM database for the status of the service. When configured to monitor using a script or an executable, the agent executes the script on each system in the cluster, once every monitor cycle. The agent returns `ONLINE`, `OFFLINE`, or `UNKNOWN` depending on the exit code of the script. The exit code must conform to VCS standards. Refer to chapter on agent functions in the *Veritas Cluster Server Agent Developer's Guide* for details.

You can monitor a service or run a script in a user-context by specifying the user name, password, and domain. Configure a service group for ServiceMonitor agent using the Application Configuration wizard, described in the *Veritas Cluster Server Administrator's Guide*.

The ServiceMonitor agent supports intelligent resource monitoring and uses Intelligent Monitoring Framework (IMF) for resource state change notifications. The agent traps the Windows service related events and takes appropriate action if a configured service stops or fails to respond. For more information about IMF, refer to the *Veritas Cluster Server Administrator's Guide*.

Note: The ServiceMonitor resource cannot be made dependent on other resources.

Agent functions

- `online`—Not applicable.
- `offline`—Not applicable.
- `monitor`—If the agent is configured to monitor a service, the agent queries the SCM for the status of the service. If the agent is configured to start a script, the agent spawns the specified script and interprets the exit code of the script.

State definitions

- `ONLINE`—Indicates the specified service is running, or that the configured script returned an online exit code.

- **FAULTED**—Indicates the specified service is not running, or that the configured script returned an offline exit code.
- **UNKNOWN**—Indicates the agent could not determine the state of the resource.

Resource type definition

```
type ServiceMonitor (  
  static il8nstr ArgList[] = {MonitorService, ServiceOrScriptName,  
    MonitorProgTimeout, UserAccount, Password, Domain }  
  boolean MonitorService = 1  
  il8nstr ServiceOrScriptName  
  int MonitorProgTimeout = 30  
  il8nstr UserAccount  
  str Password  
  il8nstr Domain  
)
```

Attribute definitions

Table 6-5 ServiceMonitor agent required attributes

Required Attribute	Type and Dimension	Description
ServiceOrScriptName	string-scalar	<p>The name of the service to be monitored or script to be spawned for monitoring the service. You must specify the complete path of the script, including any command-line arguments. This attribute can take localized values.</p> <p>Note: The exit code of the script must conform to VCS conventions: 110 for ONLINE and 100 for OFFLINE. For exit values outside the range 100-110, the status is considered UNKNOWN. Refer to the <i>Veritas Cluster Server Agent Developer's Guide</i> for more information.</p>

Table 6-6 ServiceMonitor agent optional attributes

Optional Attributes	Type and Dimension	Description
Domain	string-scalar	<p>The domain to which the user specified in the UserAccount attribute belongs. If the domain name is not specified, the agent assumes that the user belongs to the local machine. This attribute is ignored if the UserAccount attribute is not specified or if the domain name is specified in the UserAccount attribute itself.</p> <p>Note: This attribute can take localized values.</p>
MonitorProgTimeout	integer-scalar	<p>The maximum wait time, in seconds, for the agent to receive a return value from the monitor script. This attribute is ignored if the MonitorService attribute is set to 1. Default is 30 seconds.</p>

Table 6-6 ServiceMonitor agent optional attributes (Continued)

Optional Attributes	Type and Dimension	Description
MonitorService	boolean-scalar	<p>Defines whether the agent monitors a service or starts a script. If set to 1, the agent monitors a service specified by the attribute ServiceOrScriptName. If set to 0 the agent starts a script specified by the attribute ServiceOrScriptName. Default is 1.</p>
Password	string-scalar	<p>The password for the user account, encrypted using the VCS Encrypt utility. This attribute is valid only if the MonitorService is set to 0 and UserAccount is not empty.</p> <p>For more information about the VCS Encrypt utility, see the <i>Veritas Cluster Server Administrator's Guide</i>.</p>
UserAccount	string-scalar	<p>A valid user account in whose context the service will be monitored. Username can be of the form <i>username@domain.com</i> or <i>domain.com\username</i>.</p> <p>If you do not specify a value for this attribute, then the user account of the service in the SCM is ignored. To monitor service under built-in accounts, you must provide explicit values. For example:</p> <p>User Account="LocalSystem", "Local Service", or "Network Service". Domain="NT Authority".</p> <p>The 'NT Authority' domain is not applicable for the 'LocalSystem' account.</p> <p>Note: This attribute can take localized values.</p>

Sample configurations

In the following example, the ServiceMonitor agent is configured to spawn a script and interpret the script's exit code.

```
ServiceMonitor ScriptBasedMonitor (  
  MonitorService = 0  
  ServiceOrScriptName = "C:\\Programs\\monitor-script.bat"  
  MonitorProgTimeout = 15  
)
```

In the next example, the agent is configured to monitor a service.

```
ServiceMonitor Telephony_Service (  
  MonitorService = 1  
  ServiceOrScriptName = "Telephony Service"  
  UserAccount = Administrator  
  Password = bphNepE  
  Domain = VCS-DOMAIN7  
)
```

Note: While monitoring a service, the Password attribute is ignored.

Process agent

The Process agent brings processes online, takes them offline, and monitors their status. You can specify different executables for each process routine. You can configure the Process agent to monitor processes in a virtual server context. By default, processes are monitored in the context of the LocalSystem account. You can run a process with user privileges by specifying the user name, password, and domain.

You can configure a service group for the Process agent using the Application Configuration wizard or manually using the command line. Refer to the *Veritas Cluster Server Administrator's Guide* for more details.

The Process agent supports intelligent resource monitoring and uses Intelligent Monitoring Framework (IMF) for resource state change notifications. The agent supports IMF-based monitoring only when the resource is in the online state. For more information about IMF, refer to the *Veritas Cluster Server Administrator's Guide*.

Note: The Process agent does not use IMF notification for monitoring the program specified in the MonitorProgram attribute.

Agent functions

- **online**—Starts the process configured as the start program.
- **offline**—Terminates the process, or starts the process configured as the stop program.
- **monitor**—Verifies the status of the process, or starts the process configured as the monitor program.

State definitions

- **ONLINE**—Indicates the process being monitored is running properly.
- **OFFLINE**—Indicates the process being monitored is not running properly.
- **UNKNOWN**—Indicates the agent could not determine the status of the resource.

Resource type definition

```

type Process (
  static il8nstr ArgList[] = { StartProgram, StopProgram,
    MonitorProgram, UserName, Password, Domain,
    MonitorProgramTimeout, InteractWithDesktop, CleanProgram,
    StartupDirectory, StopProgramTimeout, CleanProgramTimeout,
    "LanmanResName:VirtualName" }
  il8nstr StartProgram
  il8nstr StartupDirectory
  il8nstr StopProgram
  il8nstr CleanProgram
  il8nstr MonitorProgram
  il8nstr UserName
  str Password
  il8nstr Domain
  int MonitorProgramTimeout = 30
  boolean InteractWithDesktop = 0
  int StopProgramTimeout = 30
  int CleanProgramTimeout = 30
  str LanmanResName
)

```

Attribute definitions

Table 6-7 Process agent required attributes

Required Attribute	Type and Dimension	Description
StartProgram	string-scalar	<p>The process to be monitored by the agent. You must specify the complete path of the executable, its file extension, and command-line arguments, if any. If you define the start program as a batch file or a script to launch another program, you must specify the monitor program in the configuration file.</p> <p>If you define the start program as a script (a perl script, or a vbs script), the start program should be the program that interprets the script (perl.exe, or cscript.exe) and the script itself should be passed as an argument.</p> <p>Note: This attribute can take localized values.</p>

Table 6-8 Process agent optional attributes

Optional Attributes	Type and Dimension	Description
CleanProgram	string-scalar	<p>The full path of the clean process that is launched when the resource needs a forceful offline. If no value is specified for this attribute, for a clean operation the agent kills the process indicated by the StartProgram attribute.</p> <p>Note: This attribute can take localized values.</p>
CleanProgramTimeout	integer-scalar	<p>The maximum time, in seconds, that the agent must wait before killing the process specified in the CleanProgram attribute.</p> <p>The default value is 30 seconds.</p>
Domain	string-scalar	<p>The domain to which the user specified in the UserName attribute belongs. If the domain name is not specified, the agent assumes that the user belongs to the local machine.</p> <p>This attribute is ignored if the UserName attribute is not specified or if the domain name is specified in the UserName attribute itself.</p> <p>Note: This attribute can take localized values.</p>
InteractWithDesktop	boolean-scalar	<p>Defines whether the configured process interacts with the desktop. Enabling desktop interaction enables user intervention for the process. The value 1 indicates the process will interact with the desktop. The value 0 indicates it will not. Default is 0.</p>

Table 6-8 Process agent optional attributes (Continued)

Optional Attributes	Type and Dimension	Description
MonitorProgram	string-scalar	<p>A program that monitors the process specified as the start program. You must specify the complete path of the executable, its file extension, and command-line arguments, if any.</p> <p>If you do not specify a value for this attribute, VCS monitors the start program. However, if the start program is a batch file or a script to launch another program, you must specify a monitor program.</p> <p>The Process agent supports Intelligent Monitoring Framework (IMF). However, IMF is not supported for the MonitorProgram attribute. If a script or a batch file is specified for this attribute, the Process agent does not use IMF notification to monitor the program. The agent detects the faults only during the regular monitor function.</p> <p>This attribute can take localized values.</p> <p>Note: The monitor program is spawned every monitor cycle and must return before the program specified in MonitorProgram times out. The return values for the monitor program must conform to VCS conventions: 110 for ONLINE and 100 for OFFLINE. For exit values outside the range 100-110, the status is considered UNKNOWN. Refer to the <i>VCS Agent Developer's Guide</i> for more information.</p>
MonitorProgramTimeout	integer-scalar	<p>The maximum wait time, in seconds, for the agent to receive a return value from the monitor routine. This attribute is ignored if the monitor program is not specified. Default is 30 seconds.</p>

Table 6-8 Process agent optional attributes (Continued)

Optional Attributes	Type and Dimension	Description
Password	string-scalar	<p>The encrypted password of the user specified by the UserName. Note that the password must be encrypted using the VCSEncrypt utility. See the <i>VCS Administrator's Guide</i> for more information about the utility.</p> <p>This attribute is ignored if the user name is not specified.</p>
StartupDirectory	string-scalar	<p>The startup directory for the process indicated by the StartProgram attribute.</p> <p>Note: This attribute can take localized values.</p>
StopProgram	string-scalar	<p>A program that stops the process specified as the start program. You must specify the complete path of the program, its file extension, and command-line arguments, if any. If you do not specify a value for this attribute, VCS stops the start program.</p> <p>This attribute can take localized values.</p> <p>Note: If successful, the StopProgram returns a positive value. The agent framework calls the Monitor routine after those many seconds, as returned by StopProgram. Also, while writing a stop program, make sure to stop all the processes launched by the start program.</p>
StopProgramTimeout	integer-scalar	<p>The maximum time, in seconds, that the agent must wait before killing the process specified in the StopProgram attribute.</p> <p>The default value is 30 seconds.</p>
UserName	string-scalar	<p>The user name in whose context the configured process executes. Username can be of the form username@domain.com or domain.com\username.</p> <p>If a user name is not specified, the configured process runs in the context of the user account used by the VCS High Availability Engine (HAD).</p> <p>Note: This attribute can take localized values.</p>

Table 6-8 Process agent optional attributes (Continued)

Optional Attributes	Type and Dimension	Description
LanmanResName	string-scalar	The name of the Lanman resource. The Process agent monitors the configured process in the context of the virtual name specified in the Lanman resource.

Note: When defining the StartProgram, StopProgram, or MonitorProgram attributes, enclose the path of the executable file in double quotes. Do not enclose arguments in double quotes.

Sample configuration

Sample 1

In the following configuration, the online function spawns the executable test.exe with online as a command-line argument. The offline function spawns the executable test.exe with offline as the command-line argument. The monitor function monitors the attribute value for StartProgram, test.exe, and checks the state.

```
Process Process_Test (  
    StartProgram = "\"X:\\bin\\test.exe\" /online"  
    StopProgram = "\"X:\\bin\\test.exe\" /offline"  
    UserName = "Administrator"  
    Password = bphNepE  
    Domain = "VCS_DOMAIN"  
)
```

Sample 2

In the following configuration, the batch file start.bat starts an instance, MyProcess, of the executable process.exe. The batch file stop.bat stops the process instance of process.exe. The batch file monitor.bat monitors the attribute value for StartProgram, and checks the state of the process.exe. Note that the executable process.exe resides in the directory C:\batchfiles, which is specified as the StartupDirectory.

```
PROCESS-Process_SG (  
    StartProgram = "C:\\batchfiles\\start.bat MyProcess"  
    StartupDirectory = "C:\\batchfiles"  
    StopProgram = "C:\\batchfiles\\stop.bat MyProcess"  
    MonitorProgram = "C:\\batchfiles\\monitor.bat MyProcess"  
    UserName = Administrator  
    Password = jxpVmxM  
    Domain = "mydomain.mycompany.com"  
)
```

MSMQ agent

The MSMQ agent is a bundled agent that works with the Microsoft Message Queuing (MSMQ) service. The MSMQ agent creates an MSMQ service for an MSMQ resource, brings the service online, takes it offline, and monitors its status. The agent provides high availability for the MSMQ service and the queues hosted by the service, in a clustered environment.

You can configure an MSMQ resource using the command line. See the *Veritas Cluster Server Administrator's Guide* for instructions.

Dependencies

The MSMQ resource depends on the MountV, Lanman, and the Registry Replication resources for operation. The MSMQ resource starts after each of these resources is brought online. The following figure illustrates the agent's dependency graph.

Figure 6-3 MSMQ agent dependency graph

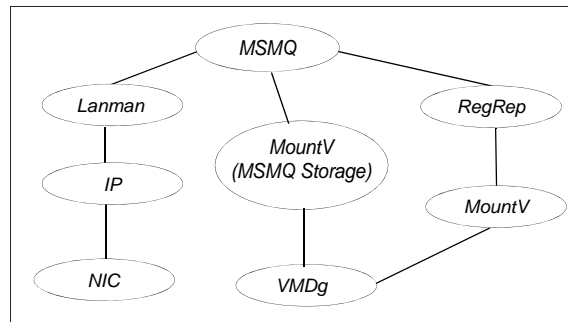

Note: In case of a NetApp storage environment, the NetApp Filer and NetApp SnapDrive agents are used instead of the VMDg and MountV agents respectively.

Agent functions

- online—Starts the MSMQ service.
- offline—Stops the MSMQ service.
- monitor—Verifies that the MSMQ service is running.

State definitions

- ONLINE—Indicates that the MSMQ service is running properly.
- OFFLINE—Indicates that the MSMQ service has stopped.
- UNKNOWN—Indicates that the agent could not determine the status of the MSMQ service.

Resource type definition

```
type MSMQ (
  static i18nstr ArgList[] ={"IPResName:Address",
    "LanmanResName:VirtualName", "MountResName:MountPath",
    StoragePath, DetailMonitor }
  str IPResName
  str LanmanResName
  str MountResName
  i18nstr StoragePath
  boolean DetailMonitor = 0
)
```

Attribute definitions

Table 6-9 MSMQ agent required attributes

Required Attribute	Type and Dimension	Description
IPResName	string-scalar	The name of the IP resource. Configure the IP resource to provide a virtual IP binding for the MSMQ service. Note: Every time you make changes to this attribute, you must disable the MSMQ resource and enable it again.
LanmanResName	string-scalar	The name of the Lanman resource. MSMQ uses the virtual name configured in the specified Lanman resource to set the virtual environment for the MSMQ service.

Table 6-9 MSMQ agent required attributes

Required Attribute	Type and Dimension	Description
MountResName	string-scalar	The name of the MountV resource. Configure the MountV resource to monitor the volume on which the MSMQ service stores its queue related data. In case of a NetApp storage environment, this will be the name of the NetAppSnapDrive resource.
StoragePath	string-scalar	The root storage path of the MSMQ service. Note: This attribute can take localized values.
DetailMonitor	boolean-scalar	Used to enable detail monitoring for the MSMQ service.

Sample configuration

The following configuration creates the MSMQ resource with the required Lanman, MountV, and the RegRep resources.

```
MSMQ test (
  IPResName=msmqip
  LanmanResName=msmqLanman
  MountResName=msmqMountV
  StoragePath=\\msmqStorage
)
```

VCS infrastructure and support agents

This chapter contains the following topics:

- [“About VCS infrastructure and support agents”](#) on page 136
- [“NotifierMngr agent”](#) on page 137
- [“Registry Replication \(RegRep\) agent”](#) on page 142
- [“Proxy agent”](#) on page 151
- [“Phantom agent”](#) on page 154
- [“FileNone agent”](#) on page 155
- [“ElifNone agent”](#) on page 156
- [“FileOnOff agent”](#) on page 157
- [“FileOnOnly agent”](#) on page 158
- [“RemoteGroup agent”](#) on page 159

About VCS infrastructure and support agents

The VCS infrastructure and support agents provide high availability for VCS-related operations. You can use some of these agents to test VCS functionality.

- NotifierMngr agent—Monitors a notifier process.
- RegRep Agent—Replicates the system registry.
- Proxy Agent—Monitors the state of a resource on a local or remote system.
- Phantom Agent—Enables VCS to determine the status of parallel service groups that do not include OnOff resources.
- ElifNone Agent—Monitors a file.
- FileNone Agent—Monitors a file.
- FileOnOff Agent—Monitors a file.
- FileOnOnly Agent—Monitors a file.
- RemoteGroup Agent—Monitors and manages service groups in a remote cluster.

NotifierMngr agent

The NotifierMngr agent starts, stops, and monitors a notifier process, making it highly available. The notifier process manages the reception of messages from VCS and Global Cluster Option (GCO) and the delivery of the messages to SNMP consoles and SMTP servers. VCS can send notification to SNMP console and SMTP servers. See the *Veritas Cluster Server Administrator's Guide* for a description of types of events that generate notification. The agent is represented by the NotifierMngr resource type. Note that only one instance of the notifier process can run in a cluster. Therefore, a notifier process cannot run in a parallel service group.

Note: The attributes of the NotifierMngr agent cannot be changed dynamically using the `hares -modify` command. Changes made using this command are effective after notifier is restarted.

Agent functions

- `online`—Starts the notifier process with its required arguments.
- `offline`—Stops the notifier process.
- `monitor`—Monitors the notifier process.

State definitions

- `ONLINE`—Indicates the notifier process is running.
- `OFFLINE`—Indicates the notifier process is not running.
- `UNKNOWN`—Indicates the agent encountered errors while monitoring the NotifierMngr resource.

Resource type definition

```

type NotifierMngr (
  static il8nstr ArgList[] = {MessageQueue, NotifierListeningPort,
    SnmpdTrapPort, SnmpCommunity, SnmpConsoles, SmtServer,
    SmtServerVrfyOff, SmtServerTimeout, SmtReturnPath,
    SmtFromPath, SmtRecipients }
  int MessageQueue = 30
  int NotifierListeningPort = 14144
  int SnmpdTrapPort = 162
  str SnmpCommunity = public
  str SnmpConsoles{}
  str SmtServer
  int SmtServerTimeout
  str SmtReturnPath
  str SmtFromPath
  str SmtRecipients{}
  boolean SmtServerVrfyOff
)

```

Attribute definitions

Table 7-1 NotifierMngr agent required attributes

Required Attributes	Type and Dimension	Description
SnmpConsoles	string-association	<p>The system name or IPv4 address of the SNMP manager and the severity level of the messages to be delivered to the SNMP manager. The severity levels of messages are Information, Warning (default), Error, and SevereError. Specifying a severity level for messages generates delivery of all messages of equal or higher severity.</p> <p>For example, "172.29.10.89"=Error, "172.29.10.56"=Information</p> <p>Note: Specifying IPv6 address for this attribute is not supported.</p>
SmtServer	string-scalar	<p>The system name or IPv4 address of the SMTP server.</p> <p>Note: Specifying IPv6 address for this attribute is not supported.</p>

Table 7-2 NotifierMngr agent optional attributes

Optional Attributes	Type and Dimension	Description
MessageQueue	integer-scalar	Size of the VCS engine's message queue size. Default is 30 messages.
NotifierListeningPort	integer-scalar	Any valid, unused TCP/IP port number. Default is 14144.
SnmpdTrapPort	integer-scalar	The port on which SNMP trap PDUs are sent. The value specified for this attribute is used for all consoles if more than one SNMP console is specified. Default is 162.
SnmpCommunity	string-scalar	The community ID for the SNMP manager. Default is "public."
SmtppFromPath	string	This attribute must be set to a valid email address, if a custom email address is desired for the FROM: field in the email sent by notifier.
SmtppRecipients	string-association	<p>The email address to which information is sent and the severity level of the messages to be received. The severity levels of messages are Information, Warning (default), Error, and SevereError. Specifying a severity level for messages indicates that all messages of equal or higher severity are received.</p> <p>For example,</p> <p>"james@veritas.com"=SevereError "admin@veritas.com"=Warning</p> <p>Note: SmtppRecipients is a required attribute if SmtppServer is specified.</p>
SmtppReturnPath	string	<p>This attribute must be set to a valid email address, if a custom email address is desired for the Return-Path: field in the email sent by notifier.</p> <p>Note: If the mail server specified in the SmtppServer does not support VRFY, then you need to set the SmtppServerVrfyOff to 1 in order for the SmtppReturnPath to come into effect.</p>

Table 7-2 NotifierMngr agent optional attributes (Continued)

Optional Attributes	Type and Dimension	Description
SmtpServerTimeout	integer	This attribute represents the time, in seconds, for which the notifier waits for a response from the mail server for the SMTP commands sent to the mail server. Increase the specified value if the mail server takes long to send response for the SMTP commands sent by the notifier. Default is 10.
SmtpServerVrfyOff	boolean	Setting this value to 1 results in notifier not sending a SMTP VRFY request to the mail server specified in SmptServer attribute, while sending emails. Set this to 1 if your mail server does not support SMTP VRFY command. Default is 0.

Sample configuration

The NotifierMngr resource sets up notification for all events to the SnmpConsole, `your_console`. In the following example, only messages of SevereError level are sent to the SmtServer, "`smtp.your_company.com`," and the recipient, "`vcadmin@your_company.com`."

Note: As only one instance of the notifier process can run in a cluster, the process cannot run in a parallel group.

```
IP csg_ip (
    Address = "10.212.100.14"
    SubNetMask = "255.255.254.0"
    MACAddress @SYSTEM1 = "00:B0:D0:D1:69:7D"
    MACAddress @SYSTEM2 = "00:B0:D0:AB:4E:22"
)

NIC csg_nic (
    MACAddress @SYSTEM1 = "00:B0:D0:D1:69:7D"
    MACAddress @SYSTEM2 = "00:B0:D0:AB:4E:22"
)

NotifierMngr ntfr(
    SnmpConsoles = { your_console = Information }
    SmtServer = "smtp.your_company.com"
    SmtRecipients = { "vcadmin@your_company.com" =
    Information }
)

csg_ip requires csg_nic
ntfr requires csg_nic
```

Registry Replication (RegRep) agent

To ensure efficient failover of an application, the registry of the node on which the application was taken offline and the registry of the node on which the application is brought online must be synchronized.

The Registry Replication agent synchronizes the registry of both the nodes by monitoring the designated registry keys. When an application changes the registry keys on the active cluster node, the agent logs these changes to the shared disk. When failover occurs, the agent updates the registry of the system on which the application is brought online using the logs on the shared disk. The RegRep agent provides you the option to:

- exclude certain subkeys from being replicated.
- mark keys for replication or exclusion, even though they do not exist when the agent is configured.
- mark keys for replication or exclusion dynamically, even when the resource is online.

When the Registry Replication agent is started, it forks an independent process to monitor registry changes. Even if the VCS engine, HAD, dies, the process continues logging registry changes to the shared disk.

If you wish to replicate the registry of an application running on a node outside VCS, run the utility VCSRegUtil on that particular node. See the *Veritas Cluster Server Administrator's Guide* for more information on VCSRegUtil utility.

Note: The Registry Replication agent runs in the context of the local system user while the HKEY_CURRENT_USER (HKCU) hive has values in the context of the current user. As the local system user account does not map to a current user account, the Registry Replication agent does not replicate the keys under the HKCU hive.

The RegRep agent supports intelligent resource monitoring and uses Intelligent Monitoring Framework (IMF) for resource state change notifications. For more information about IMF, refer to the *Veritas Cluster Server Administrator's Guide*.

Dependency

The RegRep resource depends on the MountV resource.

Agent functions

- **online**—Starts logging changes to specified registry keys to the shared disk.

- **offline**—Stops logging changes to specified registry keys to the shared disk.
- **monitor**—Verifies that the process that logs changes to registry keys is running.

State definitions

- **ONLINE**—Indicates the agent is logging changes to specified registry keys to the shared disk.
- **OFFLINE**—Indicates the agent is not logging changes to specified registry keys to the shared disk.
- **UNKNOWN**—Indicates the agent could not determine the status of the resource.

Note: The Registry Replication agent is for failover service groups only. Do not use the agent for parallel applications or service groups.

Resource type definition

```
type RegRep (  
    static i18nstr ArgList[] = {"MountResName:MountPath",  
        ReplicationDirectory, Keys, ExcludeKeys, ListOpenKeys,  
        ForceRestore, RestoreLocally, DebugMonitor }  
    str MountResName  
    i18nstr ReplicationDirectory = "\\REGREP\\DEFAULT"  
    i18nstr Keys{}  
    i18nstr ExcludeKeys[]  
    boolean ListOpenKeys = 1  
    boolean ForceRestore = 1  
    boolean RestoreLocally = 0  
    int DebugMonitor = 1  
)
```

Attribute definitions

Table 7-3 RegRep agent required attributes

Required Attributes	Type and Dimension	Description
Keys	string-association	<p>The list of registry keys to be monitored. From the 'name-value' pair of a registry key, you must provide the name of the registry keys to be synchronized and not the value for that key.</p> <p>When defining the keys, you must use the abbreviations listed in "Configuring registry keys" on page 148.</p> <p>The agent also enables you to replicate a registry key without replicating the subkeys. See "Ignoring subkeys" on page 149 for instructions.</p> <p>This attribute can take localized values.</p> <hr/> <p>Warning: Do not configure more than 63 keys for a single RegRep resource otherwise the resource will go in an UNKNOWN state.</p> <hr/>
MountResName	string-scalar	<p>The name of the MountV resource on which the Registry Replication resource depends. The MountV resource specifies the mount drive on the shared disk where the log file is created.</p> <p>In case of a NetApp storage environment, this will be the name of the NetAppSnapDrive resource.</p>
ReplicationDirectory	string-scalar	<p>The directory on the shared disk in which the registry changes are logged. The agent creates a directory with the specified name if one does not exist. Default is "\\REGREP\\DEFAULT".</p> <p>Note: This attribute can take localized values.</p>

Table 7-4 RegRep agent optional attributes

Optional Attributes	Type and Dimension	Description
DebugMonitor	integer-scalar	Defines whether debug logging is to be enabled for the executable (RegRepMonitor.exe) that monitors the registry keys. The value 0 indicates that the logging is enabled. The value 1 indicates that it is not. Default is 1.
ExcludeKeys	string-vector	<p>A list of the subkeys to be excluded from replication. For more information on how the agent excludes keys, see “Excluding keys” on page 148. When defining the keys, you must use the abbreviations listed in “Configuring registry keys” on page 148.</p> <p>Note: This attribute can take localized values.</p>
ForceRestore	boolean-scalar	<p>Defines the agent behavior when the registry update fails on a node where the resource is being brought online. A registry update may fail if any of the keys being updated are open.</p> <p>If set to 1 and the registry update fails, the agent tries to forcibly restore the keys by:</p> <ul style="list-style-type: none"> ■ backing up the configured registry keys of the node being brought online. ■ deleting the configured registry keys from the node being brought online. ■ updating the configured registry keys with the changed values. <p>If the update fails again, the agent reapplies the original values of the registry keys from the backup.</p> <p>If set to 0, the agent does not try to forcibly update the registry when an update fails. Default is 0.</p>
ListOpenKeys	boolean-scalar	Defines whether the agent lists a set of registry keys, including keys having open handles, when a registry update fails. The list is logged to the agent log. The value 1 indicates the agent lists the registry key set. The value 0 indicates the agent does not. Default is 1.

Table 7-4 RegRep agent optional attributes (Continued)

Optional Attributes	Type and Dimension	Description
RestoreLocally	boolean-scalar	Defines whether the agent restores the keys on the node if it was taken offline from the same node. For example, if the agent was taken offline from SystemA and brought online again on SystemA, this attribute determines whether the registry keys would be restored on SystemA. The value 1 indicates the agent restores the keys on the system. The value 0 indicates it does not. Default is 0.

Excluding keys

This section describes the algorithm the Registry Replication agent uses while excluding keys. For example, assume a registry key `KEY_X` has a subkey of `KEY_Y`, which has a subkey `KEY_Z`. This key would appear as `KEY_X\KEY_Y\KEY_Z` in the Registry Editor. [Table 7-5](#) describes various scenarios of keys marked for replication and for exclusion. The Result column describes the agent behavior in these scenarios.

Table 7-5 RegRep agent exclude keys and behavior

Keys for Replication	Exclude Keys	Result
KEY_X	KEY_Y\KEY_Z	KEY_Y is excluded. So is KEY_Z.
KEY_X	KEY_Y	KEY_Y is excluded. So is KEY_Z.
KEY_X	KEY_X	KEY_X is <i>not</i> excluded and an error message is logged.
KEY_X\KEY_Y	KEY_X	KEY_X is <i>not</i> excluded and an error message is logged.

Configuring registry keys

To configure a registry key to be replicated or excluded, use the abbreviation corresponding to the registry hive, as listed in [Table 7-6](#).

Table 7-6 RegRep agent registry hive

Registry Hive	Abbreviation
HKEY_LOCAL_MACHINE	HKLM
HKEY_USERS	HKU
HKEY_CURRENT_CONFIG	HKCC
HKEY_CLASSES_ROOT	HKCR

Ignoring subkeys

Use the IgnoreSubKeys option for the Keys attribute to prevent the RegistryReplication agent from replicating the subkeys. [Table 7-7](#) describes possible combination of values for the Keys attribute. The Result column describes the agent behavior in these scenarios:

Table 7-7 RegRep agent IgnoreSubKeys and behavior

Value Specified for "Keys" Attribute	Result
"HKLM\SOFTWARE\VERITAS\VCS"	Replicates the subkeys
"HKLM\SOFTWARE\VERITAS\VCS"=IgnoreSubKeys	Does not replicate the subkeys
"HKLM\SOFTWARE\VERITAS\VCS"=IgnoreSubKeys:Yes	Does not replicate the subkeys
"HKLM\SOFTWARE\VERITAS\VCS"=IgnoreSubKeys:No	Replicates the subkeys
"HKLM\SOFTWARE\VERITAS\VCS"=<any other value>	Replicates the subkeys

Additional considerations for using IgnoreSubKeys

Symantec recommends not to set the "IgnoreSubKeys" value when the RegRep resource is online. Even if the value is set with the resource online, the changes will be applicable after the next online routine.

Sample configuration

In the following sample configuration, the Registry Replication agent is configured to replicate the print spooler registry key.

```
IP IP-10-212-100-184 (
  Address = "10.212.100.184"
  SubNetMask = "255.255.254.0"
  MACAddress @SYSTEM1 = "00-02-B3-AD-CB-D0"
  MACAddress @SYSTEM2 = "00-02-B3-AD-CE-E4"
)

Lanman Lanman-PRINTSHAREMAN (
  VirtualName = PRINTSHAREMAN
  IPResName = IP-10-212-100-184
  ADCriticalForOnline = 1
)

MountV MountV-JDrive (
  MountPath = "J:"
  VolumeName = PS-SPOOL
  VMDGResName = VMDg-PRINTSHARE_DG
)
```

```
MountV MountV-IDrive (
  MountPath = "I:"
  VolumeName = PS-REGREP
  VMDGResName = VMDg-PRINTSHARE_DG
)
NIC NIC-PRINSHARE-SG (
  MACAddress @SYSTEM1 = "00-02-B3-AD-CB-D0"
  MACAddress @SYSTEM2 = "00-02-B3-AD-CE-E4"
)

PrintShare PSShare (
  PrinterName = "HP LaserJet 4050 Series PCL"
  ShareName = "HP LaserJet 4050 Series PCL"
  LanmanResName = Lanman-PRINTSHAREMAN
)

PrintSpool PSSpool (
  LanmanResName = Lanman-PRINTSHAREMAN
  IPResName = IP-10-212-100-184
  MountResName = MountV-JDrive
  SpoolDir = "\\SPOOLER"
)

RegRep RegRep (
  MountResName = MountV-IDrive
  ReplicationDirectory = "\\PS-REGREP"
  Keys = {"HKLM\\Software\\Veritas\\VCS\\BundledAgents
  \\PrintSpool\\PSSpool" }
)

ServiceMonitor ServiceMonitor-PrintSpooler (
  ServiceOrScriptName = "Print Spooler"
)

VMDg VMDg-PRINTSHARE_DG (
  DiskGroupName = PRINTSHARE_DG
)

IP-10-212-100-184 requires NIC-PRINSHARE-SG
Lanman-PRINTSHAREMAN requires IP-10-212-100-184
MountV-JDrive requires VMDg-PRINTSHARE_DG
MountV-IDrive requires VMDg-PRINTSHARE_DG
PSShare requires PSSpool
PSSpool requires Lanman-PRINTSHAREMAN
PSSpool requires MountV-JDrive
PSSpool requires ServiceMonitor-PrintSpooler
PSSpool requires RegRep
RegRep requires MountV-IDrive
VNAME requires IP_A
```

Proxy agent

The Proxy agent monitors and mirrors the state of a resource on a local or remote system. The agent can be used to reduce monitoring overheads in configurations where multiple resources point at the same physical device. For example, if multiple service groups use the same NIC, configure one service group to monitor the NIC and have Proxy resources in the other service groups to mirror the state of the NIC resource. The agent can also determine the status of an OnOff resource in a different service group.

Symantec recommends the use of Proxy agent to monitor persistent resources such as NIC, ServiceMonitor, ElifNone, and FileNone.

Agent functions

- online—Not applicable.
- offline—Not applicable.
- monitor—Determines the status of the target resource.

State definitions

- ONLINE—Indicates the target resource is online.
- FAULTED—Indicates the target resource is offline or faulted.

Resource type definition

```
type Proxy (  
    static int OfflineMonitorInterval = 60  
    static i18nstr ArgList[] = { TargetResName, TargetSysName,  
        "TargetResName:Probed", "TargetResName:State"}  
    static str Operations = None  
    str TargetResName  
    str TargetSysName  
)
```

Attribute definitions

Table 7-8 Proxy agent required attributes

Required Attribute	Type and Dimension	Description
TargetResName	string-scalar	The name of the target resource whose status is monitored and mirrored by the Proxy resource.

Table 7-9 Proxy agent optional attributes

Optional Attribute	Type and Dimension	Description
TargetSysName	string-scalar	The name of the system associated with the target resource. If this attribute is not specified, the Proxy resource assumes the system is local.

Sample configurations

```
group NicGrp (
    SystemList = { SYSTEM1, SYSTEM2 }
    Parallel = 1
)

Phantom my_phantom (
)

NIC NicGrp_public (
    MACAddress @SYSTEM1 = "00-50-04-24-F9-60"
    MACAddress @SYSTEM2 = "00-50-04-24-E3-30"
    UseConnectionStatus= True
)

group Grp1 (
    SystemList = { SYSTEM1,SYSTEM2 }
    AutoStartList = { SYSTEM1 }
)

NotifierMngr ntfr(
    SnmpConsoles = { your_console = Information }
    SmtServer     = "smtp.your_company.com"
    SmtpRecipients = { "vcsadmin@your_company.com" =
    Information }
)

Proxy nicproxy (
    TargetResName="NicGrp_public"
)

ntfr requires nicproxy
```

Phantom agent

The Phantom agent enables VCS to determine the status of parallel service groups that do not include OnOff resources (resources that VCS starts and stops as required.) The Phantom agent provides a “dummy” resource that can be brought online and taken offline. Without such a dummy resource, VCS cannot assess the status of service groups containing only None (Persistent) and OnOnly resources because the state of these resources is not considered in the process of determining whether a group is online.

Agent functions

- online—Not applicable.
- offline—Not applicable.
- monitor—Determines status based on the status of its service group.

State definitions

- ONLINE—Indicates the service group is online.
- OFFLINE—Indicates the service group is offline.

Attribute definitions

Not applicable.

Sample configuration

```
FileNone FILE_1 (  
    PathName = "C:\\Temp\\file1"  
)  
  
FileOnOnly FILE_2 (  
    PathName = "C:\\Temp\\file2"  
)  
  
ElifNone FILE_3 (  
    PathName = "C:\\Temp\\file3"  
)  
  
Phantom PHANTOM_1 (  
)
```

FileNone agent

The FileNone agent monitors a file. The monitor routine returns ONLINE if the specified file exists.

Agent functions

- online—Not applicable.
- offline—Not applicable.
- monitor—Verifies that the specified file exists.

State definitions

- ONLINE—Indicates the specified file exists.
- FAULTED—Indicates the specified file does not exist.
- UNKNOWN—Indicates that the value of the PathName attribute does not contain a file name.

Resource type definition

```
type FileNone (
    static i18nstr ArgList[] = { PathName }
    i18nstr PathName
)
```

Attribute definitions

Table 7-10 FileNone agent required attributes

Required Attributes	Type and Dimension	Description
PathName	string-scalar	The complete path of the file to be monitored. This attribute can take localized values.

Sample configuration

```
FileNone tmp_file01_txt (
    PathName = "C:\\tmp\\file01.txt"
)
```

ElifNone agent

The ElifNone agent monitors a file. The monitor routine returns ONLINE if the specified file does not exist.

Agent functions

- online—Not applicable.
- offline—Not applicable.
- monitor—Verifies that the specified file exists.

State definitions

- ONLINE—Indicates the specified file does not exist.
- FAULTED—Indicates the specified file exists.
- UNKNOWN—Indicates that the value of the PathName attribute does not contain a file name.

Resource type definition

```
ElifNone (
    static i18nstr ArgList[] = { PathName }
    i18nstr PathName
)
```

Attribute definitions

Table 7-11 ElifNone agent required attributes

Required Attributes	Type and Dimension	Description
PathName	string-scalar	The complete path of the file to be monitored. This attribute can take localized values.

Sample configuration

```
ElifNone tmp_file01_txt (
    PathName = "C:\\tmp\\file01.txt"
)
```

FileOnOff agent

The FileOnOff agent creates, removes, and monitors files.

Agent functions

- **online**—Creates an empty file with the specified name if the file does not already exist.
- **offline**—Removes the specified file.
- **monitor**—Verifies that the specified file exists.

State definitions

- **ONLINE**—Indicates the specified file exists.
- **OFFLINE**—Indicates the specified file does not exist.
- **UNKNOWN**—Indicates that the value of the PathName attribute does not contain a file name.

Resource type definition

```
type FileOnOff (
  static i18nstr ArgList[] = { PathName }
  i18nstr PathName
)
```

Attribute definitions

Table 7-12 FileOnOff agent required attributes

Required Attributes	Type and Dimension	Description
PathName	string-scalar	The complete path of the file to be monitored. This attribute can take localized values.

Sample configuration

```
FileOnOff tmp_file01_txt (
  PathName = "C:\\tmp\\file01.txt"
)
```

FileOnOnly agent

The FileOnOnly agent creates and monitors a file.

Agent functions

- **online**—Creates the specified file.
- **offline**—Not applicable.
- **monitor**—Verifies that the specified file exists.

State definitions

- **ONLINE**—Indicates the specified file exists.
- **FAULTED**—Indicates the specified file does not exist.
- **UNKNOWN**—Indicates that the value of the PathName attribute does not contain a file name.

Resource type definition

```
type FileOnOnly (  
    static i18nstr ArgList[] = { PathName }  
    i18nstr PathName  
)
```

Attribute definitions

Table 7-13 FileOnOnly agent required attributes

Required Attributes	Type and Dimension	Description
PathName	string-scalar	The complete path of the file to be monitored. This attribute can take localized values.

Sample configuration

```
FileOnOnly tmp_file01_txt (  
    PathName = "C:\\tmp\\file01.txt"  
)
```

RemoteGroup agent

The RemoteGroup agent establishes dependencies between applications that are configured on different VCS clusters. For example, you configure an Apache resource in a local cluster, and a MySQL resource in a remote cluster. In this example, the Apache resource depends on the MySQL resource. You can use the RemoteGroup agent to establish this dependency between these two resources. With the RemoteGroup agent, you can monitor or manage a service group that exists in a remote cluster.

Some points about configuring the RemoteGroup resource are as follows:

- For each remote service group that you want to monitor or manage, you must configure a corresponding RemoteGroup resource in the local cluster.
- Multiple RemoteGroup resources in a local cluster can manage corresponding multiple remote service groups in different remote clusters.
- You can include the RemoteGroup resource in any kind of resource or service group dependency tree.
- A combination of the state of the local service group and the state of the remote service group determines the state of the RemoteGroup resource.

Symantec supports the RemoteGroup agent when:

- When it points to a global group
The RemoteGroup agent must then map the state of the global group in the local cluster.
- When it is configured inside a local parallel service group
The RemoteGroup resources on all cluster nodes monitor the same remote service group unless its attributes are localized.
- When it is configured inside a local failover service group

For more information on the functionality of this agent, see the *Veritas Cluster Server Administrator's Guide*.

Dependency

As a best practice, establish a RemoteGroup resource dependency on a NIC resource. Symantec recommends that the RemoteGroup resource not be by itself in a service group.

Agent functions

- Online—Depending on the ControlMode setting, this function brings the remote service group online.

See “[ControlMode](#)” on page 164 for more information.

- Offline—Depending on the ControlMode setting, this function takes the remote service group offline.
See “[ControlMode](#)” on page 164 for more information.
- Monitor—Monitors the state of the remote service group. The true state of the remote service group is monitored only on the online node in the local cluster.
See “[VCSSysName](#)” on page 163 for more information.
- Clean—Depending on the ControlMode setting, Clean takes the remote service group offline whenever the RemoteGroup resource faults.
See “[ControlMode](#)” on page 164 for more information.

State definitions

- ONLINE—Indicates that the remote service group is either in an ONLINE or PARTIAL state.
If the ReturnIntOffline attribute is not set to RemotePartial, then the remote service group is either in an ONLINE or PARTIAL state.
See “[ReturnIntOffline](#)” on page 166 for more information.
- OFFLINE—Indicates that the remote service group is in an OFFLINE or FAULTED state. The true state of the remote service group is monitored only on the online node in the local cluster.
The RemoteGroup resource returns intentional offline if the attribute ReturnIntOffline is set to an appropriate value.
See “[ReturnIntOffline](#)” on page 166 for more information.
- FAULTED—Indicates that the remote service group has unexpectedly gone offline.
- UNKNOWN—Indicates that a problem exists either with the configuration or the ability of the RemoteGroup resource to determine the state of the remote service group.

Resource type definition

```

type RemoteGroup (
    static boolean IntentionalOffline = 1
    static int OnlineRetryLimit = 2
    static int ToleranceLimit = 1
    static i18nstr ArgList[] = { IPAddress, Port, Username,
    Password, GroupName, VCSSysName, ControlMode, OfflineWaitTime,
    DomainType, BrokerIp, ReturnIntOffline }
    str IPAddress
    int Port = 14141
    str Username
    str Password
    str GroupName
    str VCSSysName
    str ControlMode
    int OfflineWaitTime
    str DomainType
    str BrokerIp
    str ReturnIntOffline[]
    temp str OfflineMonitoringNode
)

```

Attribute definitions

Table 7-14 RemoteGroup agent required attributes

Required Attribute	Type and Dimension	Description
IPAddress	string-scalar	<p>The IP address or DNS name of a node in the remote cluster, with which the agent communicates to get the status of the remote service group. The IP address can be either physical or virtual.</p> <p>If the IP address is a virtual IP address, make sure that this virtual IP address is not configured as an IP resource in the remote service group that is to be monitored.</p> <p>Example: "www.example.com" or "11.183.12.214"</p>
Port	integer-scalar	<p>The port on the remote node with which the agent communicates. This is an optional attribute, unless the remote cluster listens on another port. The default value is 14141.</p>

Table 7-14 RemoteGroup agent required attributes (Continued)

Required Attribute	Type and Dimension	Description
Username	string-scalar	<p>This is the login user name for the remote cluster.</p> <p>When you set the ControlMode attribute to OnOff or OnlineOnly, the Username must have administrative privileges for the remote service group that you specify in the GroupName attribute.</p> <p>When you use the RemoteGroup Wizard to enter your username data, you need to enter your username and the domain name in separate fields. For a cluster that has the Symantec Product Authentication Service, you do not need to enter the domain name.</p> <p>Example: "jsmith@example.com"</p>
Password	string-scalar	<p>This is the password that corresponds to the user that you specify in the Username attribute. You must encrypt the password using the VCS Encrypt utility. For more information about the VCS Encrypt utility, see the <i>VCS Administrator's Guide</i>.</p> <p>Do not use the vcsencrypt utility when entering passwords from a configuration wizard or from the Cluster Management Console or the Cluster Manager (Java Console).</p>
GroupName	string-scalar	<p>The name of the service group on the remote cluster that you want the RemoteGroup agent to monitor or manage.</p> <p>Example: "DBGrp"</p>

Table 7-14 RemoteGroup agent required attributes (Continued)

Required Attribute	Type and Dimension	Description
VCSSysName	string-scalar	<p>You must set this attribute to either the VCS system name or the ANY value.</p> <ul style="list-style-type: none"> ■ ANY The RemoteGroup resource goes online if the remote service group is online on any node in the remote cluster. ■ VCSSysName Use the name of a VCS system in a remote cluster where you want the remote service group to be online when the RemoteGroup resource goes online. Use this to establish a one-to-one mapping between the nodes of the local and remote clusters. <p>Example: "vcssys1" or "ANY"</p>

Table 7-14 RemoteGroup agent required attributes (Continued)

Required Attribute	Type and Dimension	Description
ControlMode	string-scalar	<p>Select only one of these values to determine the mode of operation of the RemoteGroup resource: MonitorOnly, OnlineOnly, or OnOff.</p> <ul style="list-style-type: none"> <p>■ OnOff The RemoteGroup resource brings the remote service group online or takes it offline. When you set the VCSSysName attribute to ANY, the SysList attribute of the remote service group determines the node where the remote service group comes online.</p> <p>■ MonitorOnly The RemoteGroup resource only monitors the state of the remote service group. The RemoteGroup resource cannot bring the remote service group online or take it offline. Make sure that you bring the remote service group online before you bring the RemoteGroup resource online.</p> <p>■ OnlineOnly The RemoteGroup resource only brings the remote service group online. The RemoteGroup resource cannot take the remote service group offline. When you set the VCSSysName attribute to ANY, the SysList attribute of the remote service group determines the node where the remote service group comes online.</p>

Table 7-15 RemoteGroup agent optional attributes

Optional Attribute	Type and Dimension	Description
OfflineWaitTime	integer-scalar	<p>The maximum expected time in seconds that the remote service group may take to go offline. VCS calls the Clean function for the RemoteGroup resource if the remote service group takes a longer time to offline than the time that you have specified for this attribute. The default value is 0.</p>

Table 7-15 RemoteGroup agent optional attributes (Continued)

Optional Attribute	Type and Dimension	Description
DomainType	string-scalar	<p>Enter the domain type information for the specified user. This is for a secure remote cluster only.</p> <p>For users who have the domain type unixpwd, you do not have to set this attribute.</p> <p>Example: "nis", "nisplus"</p>
BrokerIp	string-scalar	<p>For a secure remote cluster only, if the user needs the RemoteGroup agent to communicate to a specific authentication broker, then set this attribute.</p> <p>Enter the information for the specific authentication broker in the format "IP".</p> <p>Example: "128.11.295.51"</p>
OnlineRetryLimit OnlineWaitLimit ToleranceLimit MonitorInterval AutoFailover	integer-scalar	<p>In case of remote service groups that take a longer time to come online, Symantec recommends that you modify the default OnlineWaitLimit and OnlineRetryLimit attributes.</p> <p>If you expect the RemoteGroup agent to tolerate sudden offlines of the remote service group, then modify the ToleranceLimit attribute.</p> <p>See the <i>Veritas Cluster Server Administrator's Guide</i> for more information about these attributes.</p>

Table 7-15 RemoteGroup agent optional attributes (Continued)

Optional Attribute	Type and Dimension	Description
ReturnIntOffline	string-vector	<p>Select one of the following values for RemoteGroup to return IntentionalOffline:</p> <ul style="list-style-type: none"> ■ RemotePartial.Indicates that the RemoteGroup resource returns an IntentionalOffline if the remote service group is in an ONLINE PARTIAL state. ■ RemoteOffline.Indicates that the RemoteGroup resource returns an IntentionalOffline if the remote service group is in an OFFLINE state. ■ RemoteFaulted.Indicates that the RemoteGroup resource returns an IntentionalOffline if the remote service group is OFFLINE FAULTED. <p>You can use these values in combinations with each other.</p> <p>You must set the IntentionalOffline attribute of the RemoteGroup resource type to 1 for this attribute to work properly.</p> <p>Default: ""</p>
OfflineMonitoringNode		<p>Defines the cluster node that performs the offline monitoring of the remote service group.</p> <p>This is an internal attribute. Do not modify.</p>

About the ControlMode attribute

In the ControlMode attribute, you can use these values, depending on your needs: OnOff, MonitorOnly, and OnlineOnly.

OnOff

Select the OnOff value of this attribute when you want the RemoteGroup resource to manage the remote service group completely.

The username provided in the Username attribute should have administrator privileges for the service group on the remote cluster.

In case of one-to-one mapping, set the value of the AutoFailover attribute of the remote service group to 0. This avoids unnecessary onlining or offlining of the remote service group.

MonitorOnly

Select the MonitorOnly value of this attribute when you want to monitor the state of the remote service group. When you choose the MonitorOnly attribute, the RemoteGroup agent does not have control over the remote service group and cannot bring it online nor take it offline.

The remote service group should be in an ONLINE state before you bring the RemoteGroup resource online.

Symantec recommends that you set the AutoFailover attribute of the remote service group to 1.

OnlineOnly

Select the OnlineOnly value of this attribute when the remote service group takes a long time to come online or to go offline. When you use OnlineOnly for the ControlMode attribute, a switch or fail over of the local service group with VCSSysName set to ANY does not cause the remote service group to be taken offline and brought online.

The username provided in the Username attribute needs to have administrator privileges for the remote service group.

The Offline of the RemoteGroup resource does not offline the remote service group.

If you are choosing one-to-one mapping between the local nodes and remote nodes, then the value of the AutoFailover attribute of the remote service group must be 0.

Note: When you set the value of ControlMode to OnlineOnly or to MonitorOnly, the recommended value of the VCSSysName attribute of the RemoteGroup resource is ANY. If you want one-to-one mapping between the local nodes and the remote nodes, then a switch or fail over of local service group is impossible. It is important to note that in both these configurations the RemoteGroup agent does not take the remote service group offline.

Sample scenario

In this example, a local VCS cluster (front-end cluster) provides high availability for Web-services and a remote VCS cluster (back-end cluster) provides high availability for the database required by the Web-services. The cluster setup is as follows:

- The local cluster is a two-node cluster, where local1 and local2 are the names of the two local nodes.
- The remote cluster is a two-node cluster, where remote1 and remote2 are the names of the two remote nodes.
- LocGrp is the local service group that contains the WebRes resource (for example: Apache, etc.) configured for the Web-server that runs in the local cluster.
- RemGrp is the remote service group that contains the DBRes resource (for example: MySQL or Oracle, etc.) configured for the database in the remote cluster.

The database resource (DBRes) needs to come online before the Web server resource (WebRes) comes online. You can use the RemoteGroup agent to establish this inter-cluster application dependency.

To configure the remotegroup agent for this setup

- 1 Create a RemoteGroup resource (RGRes) in the local service group (LocGrp) for monitoring or managing the DBRes resource in the remote cluster.
- 2 Link the resources such that the WebRes resource depends on the RGRes resource.
- 3 Set the attributes for the RemoteGroup resource (RGRes) as follows:
 - **IpAddress**—Set to the IP address or DNS name of a node in the remote cluster. For this example, the value is remote1. You can also set this value as remote2 (second node in the remote cluster).
The RemoteGroup agent keeps a list of remote nodes (remote1, remote2) on the local node. The IP address that you specify should be reachable the first time the RemoteGroup agent tries to communicate

to the remote cluster. In case the specified IP address is not reachable after the first communication, the RemoteGroup agent talks to the second remote node to retrieve the state of RemGrp.

- **GroupName**—Set the value to RemGrp (the remote service group).
- **VCSSysName**—Set appropriate values so as to establish a one-to-one mapping between the systems in the local and remote clusters. RGRes will completely manage the remote service group (RemGrp) that contains the DBRes resource. Make this a local attribute for the RGRes.
- **ControlMode**—Set the value to OnOff.
- **Username**—Set the value to user_admin. The user needs to have administrative privileges for RemGrp.
- **Password**—Password for user_admin. You must encrypt the password using the VCS Encrypt command. See the *VCS Administrator's Guide* for more information on the VCS Encrypt utility.
- **VCSSysName@local1**—Set this value to remote1.
- **VCSSysName@local2**—Set this value to remote2.

You have to set the value of BrokerIp for a remote cluster that has the Symantec Product Authentication Service enabled.

- 4 Set the value of the AutoFailover attribute of the RemGrp to 0. This avoids unnecessary online or offline of the remote service group in case of a fail over. If the value of the VCSSysName attribute is ANY, then the value of the AutoFailover attribute of RemGrp should be 1.

Service group behavior

Consider the following actions to better understand the service group behavior in this configuration.

■ Bringing the LocGrp local service group online

The Online functions of all the resources in LocGrp (local service group) are called starting from the lower-most resource on local1. In this configuration, WebRes depends on RGRes. The RGRes Online function is called before the WebRes Online function. In the Online function, the RemoteGroup agent communicates to the remote cluster and authenticates the specified user. The RemoteGroup agent brings RemGrp online on remote1. RemGrp is in an ONLINE state on remote1 and RGRes is in an ONLINE state on local1. The Online function of WebRes is then called. WebRes is now in an ONLINE state.

Thus, you have established an application-level dependency across two different VCS clusters. The WebRes does not go online before the RGRes goes online. RGRes does not go online before the RemGrp goes online.

- **An unexpected offline of the RemGrp remote service group**

LocGrp is online on the local1. WebRes and RGRes are both online on local1. RemGrp is online on remote1. If RemGrp faults on remote1, RGRes detects that RemGrp has gone OFFLINE or has FAULTED on remote1 and goes into a FAULTED state. All the resources in LocGrp are taken offline on local1. LocGrp now fails over to local2. All the resources including WebRes and RGRes go into an ONLINE state on local2. As part of the fail over of LocGrp on local2, RemGrp goes online on remote2. LocGrp shows ONLINE on node local2 and OFFLINE OR FAULTED on local1.

- **Taking the LocGrp service group offline on local1**

LocGrp is online on local1 and RemGrp is online on remote1. If you take LocGrp offline, all the resources dependent on RGRes are taken offline. First, the WebRes resource goes offline and then the offline for RGRes is called. As the ControlMode is OnOff, the RemoteGroup agent communicates to the remote cluster and issues an offline command for RemGrp. Once RemGrp has gone offline, RGRes goes into OFFLINE state. Thus, the Web-server is taken offline before the database goes offline.

VCS hardware replication agent for NetApp

This chapter contains the following topics:

- [“About hardware replication agents for NetApp”](#) on page 172
- [“NetApp Filer agent”](#) on page 173
- [“NetApp SnapDrive agent”](#) on page 175
- [“NetApp SnapMirror agent”](#) on page 177

About hardware replication agents for NetApp

The VCS hardware replication agent for Network Appliance provides failover support and recovery, in environments employing Network Appliance filers for storage and SnapMirror for replication.

The agent monitors and manages the state of replicated filer devices and ensures that at a time only one system has safe and exclusive access to the configured devices.

The agent can be used in local clusters, single VCS replicated data clusters, and multi-cluster environments set up using the VCS Global Cluster Option.

The package contains three agents; each agent is described in subsequent sections:

- NetAppFiler agent—Monitors the state of the filer.
- NetAppSnapDrive agent—Connects and disconnects virtual disks (LUNs) using the iSCSI or FC protocol.
- NetAppSnapMirror agent—Determines the role of the filer volumes with respect to replication and promotes a read-only snapmirrored volume to a read-write source volume during a wide-area failover.

Note: The NetApp agents are available with Veritas Cluster Server for Windows and require a separate HA/DR license.

NetApp Filer agent

The NetApp Filer agent monitors the state of the filer device. The NetApp Filer agent is configured as a resource of type NetAppFiler. NetAppFiler resources are persistent, meaning that they are not brought online or taken offline.

Agent function

The NetAppFiler agent function is as follows:

Monitor	<p>Performs the following tasks:</p> <ul style="list-style-type: none"> Verifies the state of the filer attached to the host by sending an ICMP ping command to the filer. If the filer does not respond, the agent reports the state of the filer as faulted. Opens a filer connection and checks if ONTAPI version is supported by the filer. If the connection fails or the ONTAPI version is not supported, the agent reports the state as offline.
---------	---

Resource type definition

```
type NetAppFiler (
    static int MonitorInterval = 30
    static i18nstr ArgList[] = { FilerName, StorageIP }
    static str Operations = None
    str FilerName
    str StorageIP
)
```

Attribute definitions

Table 8-1 NetApp Filer agent attributes

Attribute	Type - Dimension	Description
FilerName	string-scalar	DNS-resolvable name or IP address of the locally attached filer.
StorageIP	string -scalar	The private storage IP address of the filer.

Sample configuration

```
NetAppFiler A2-NetAppFiler (
```

```
FilerName = winvm-netapp02  
StorageIP = "10.121.57.8"  
)
```

NetApp SnapDrive agent

The NetApp SnapDrive agent monitors, connects, and disconnects filer volumes. The agent can be configured to use the iSCSI or the FC protocol.

NetApp SnapDrive agent is configured as a resource of type NetAppSnapDrive.

Dependency

The NetApp SnapDrive resource depends on the NetApp SnapMirror and the NetApp Filer resources for operation.

If the NetApp SnapMirror resource is not configured, the NetApp SnapDrive resource depends on the NetApp Filer resource.

Agent functions

- **Online**—Connects a virtual disk (LUN) using an iSCSI or an FC initiator. The agent presents the LUN as a locally-attached drive to the host. The agent also removes LUN-host mappings made before the online operation.
- **Offline**—Disconnects the virtual disk (LUN) from the host.
- **Monitor**—Verifies that the specified virtual disk (LUN) is connected to the host.
- **Open**—Verifies that there is connectivity to the filer. It also checks that the VCS Helper service is running with the same privileges as the SnapDrive service.
- **Clean**—Attempts to forcibly disconnect a virtual disk (LUN).

Resource type definition

```
type NetAppSnapDrive (  
    static int MonitorInterval = 30  
    static int NumThreads = 1  
    static i18nstr ArgList[] = { FilerResName,  
        "FilerResName:FilerName", "FilerResName:StorageIP",  
        VolumeName, ShareName, LUN, MountPath, Initiator,  
        InitiatorMonitorInterval }  
    str FilerResName  
    str VolumeName  
    str ShareName  
    str LUN  
    str MountPath  
    str Initiator[]  
    int InitiatorMonitorInterval = 30  
)
```

Attribute definitions

Table 8-2 NetApp SnapDrive agent attributes

Attribute	Type - Dimension	Description
FilerResName	string-scalar	Name of the VCS NetAppFiler-type resource in the service group.
VolumeName	string-scalar	Name of the volume containing the virtual disk. Define the volume name in the same case as on the filer.
ShareName	string-scalar	Name of the CIFS share containing the virtual disk.
LUN	string-scalar	Name of the LUN (virtual disk) on the filer that is presented to the host for mounting. Define the LUN name in the same case as on the filer.
MountPath	string-scalar	Drive letter to be assigned to the virtual disk.
Initiator	string-vector	Name of iSCSI or FC initiator the host uses to connect virtual disks. You can retrieve this value from the Disk Management console.

Sample configuration

```

NetAppSnapDrive A2-NetAppSnapDrive (
  FilerResName = A2-NetAppFiler
  VolumeName = vol8
  ShareName = data08
  LUN = "d85.lun"
  MountPath = T
  Initiator @VCSW2K288 = { "21:00:00:e0:8b:1c:cc:45",
    "21:00:00:e0:8b:90:74:1a" }
  Initiator @VCSW2K287 = { "21:00:00:e0:8b:0e:3a:6a" }
)

```

NetApp SnapMirror agent

The NetApp SnapMirror agent monitors the replication state of filer devices. When a failover occurs, the agent reverses the direction of replication.

NetApp SnapMirror agent is configured as a resource of type NetAppSnapMirror.

Dependency

The NetApp SnapMirror resource depends on the NetApp Filer resource for operation.

Agent functions

- **Online**—If the state of the local filer device is SOURCE, the agent creates a lock file to indicate that the resource can come online. This effectively makes the devices writable for the application.
If the state of the local filer is SNAPMIRRORED, the agent attempts to reverse the direction of replication by changing the state of the local filer to SOURCE and that of the original source to SNAPMIRRORED.
If the original source filer is down, the agent performs a mirror breakoff to enable local write access, if the filer is not already broken off.
If the original source returns to life, you must resynchronize the data manually.
- **Offline**—Removes the lock file. The agent does not perform any filer operations because an offline function does not necessarily indicate an intention to give up the devices.
- **Monitor**—Verifies the lock file exists. If the lock file exists, the monitor function reports the status of the resource as online. If the lock file does not exist, the monitor function reports the status of the resource as offline.
- **Open**—Removes the lock file, thereby preventing potential concurrency violation if the group fails over to another node.

Note: The agent does not remove the lock file if the agent was started after an `hastop -force` command.

- **Clean**—Removes the lock file. No filer operations are performed since offlining this resource is no indication of a pending role swap.

Action function

The Action function enables you to perform predefined actions on a resource.

To perform an action on a resource, type the following command:

```
hares -action <SnapMirror_resname> <token> [-actionargs
<arg1> ...] [-sys <system>] [-clus <cluster> ]
```

[Table 8-3](#) lists the action supported by the NetAppSnapMirror agent:

Table 8-3 Actions supported by NetAppSnapMirror agent

Token for Action	Description
fbsync	Resynchronises an original source volume with a broken-off volume. After synchronization, the original source volume becomes the target volume. The broken-off volume was initially the target volume, but was broken off as a result of a take over.

To synchronize volumes, type the following at the command prompt:

```
hares -action SnapMirror_resname fbsync -sys node_name
```

Where, *SnapMirror_resname* represents the name of the SnapMirror resource and *node_name* represents the node on which the service group is online.

Run the action for each SnapMirror resource.

You can also add custom actions for the agents. Refer to the *Veritas Cluster Server Agent Developer's Guide* for more information.

Resource type definition

```
type NetAppSnapMirror (
  static keylist SupportedActions = { fbsync }
  static int MonitorInterval = 300
  static int NumThreads = 1
  static i18nstr ArgList[] = { FilerResName,
  "FilerResName:FilerName",
  "FilerResName:StorageIP", VolumeName, SnapMirrorArguments,
  SnapMirrorSchedule, AppResName, VisibilityFrequency,
  SyncMode }
  str FilerResName
  str VolumeName
  str SnapMirrorArguments
  str SnapMirrorSchedule
  str AppResName
  int VisibilityFrequency = 180
  str SyncMode = async
)
```

Attribute definitions

Table 8-4 NetApp SnapMirror agent attributes

Attribute	Type - Dimension	Description
FilerResName	string-scalar	Name of the VCS NetAppFiler-type resource in the group.
VolumeName	string-scalar	Name of the volume containing the virtual disk. Define the volume name in the same case as on the filer.
SnapMirrorArguments	string-scalar	Specifies the SnapMirror arguments such as maximum transfer speed and restart mode.
SnapMirrorSchedule	string-scalar	<p>Specifies the schedule the destination uses for updating data. Do not assign a value for this attribute if you use SnapManager.</p> <p>The schedule is in the following format: minute hour dayofmonth dayofweek</p> <p>Each field is separated by a space.</p> <p>Refer to the NetApp documentation for more details on the rules for each of these schedule fields.</p> <p>By default, this attribute does not have any value.</p>
AppResName	string-scalar	Name of the resource configured to monitor the application being made highly available.

Table 8-4 NetApp SnapMirror agent attributes (Continued)

Attribute	Type - Dimension	Description
SyncMode	string-scalar	<p>Specifies the mode of replication for the mirror.</p> <p>This attribute can have the following values:</p> <ul style="list-style-type: none"> ■ async: Indicates that the mirror should be configured in the asynchronous mode. ■ semi-sync: Indicates that the mirror should be configured in the semi-synchronous mode. ■ sync: Indicates that the mirror should be configured in the synchronous mode. <p>The default is async (asynchronous) mode.</p>
VisibilityFrequency	string-scalar	<p>Specifies how often the source snapshot will be visible on the destination mirror. It controls the value of <code>visibility_interval</code> in the <code>snapmirror.conf</code> file.</p> <p>The default value is 180 seconds.</p> <p>This attribute is applicable only if the mirror is configured in synchronous or semi-synchronous mode.</p>

Sample configuration

```
NetAppSnapMirror sqlg-NetAppSnapMirror (  
  FilerResName = sqlg-NetAppFiler  
  VolumeName = vol3  
)
```

Troubleshooting bundled agents

This chapter contains the following topics:

- [“About troubleshooting bundled agents”](#) on page 184
- [“VCS logging”](#) on page 184
- [“Troubleshooting storage agents”](#) on page 185
- [“Troubleshooting network agents”](#) on page 204
- [“Troubleshooting FileShare agents”](#) on page 212
- [“Troubleshooting PrintShare agents”](#) on page 216
- [“Troubleshooting services and application agents”](#) on page 221
- [“Troubleshooting infrastructure and support agents”](#) on page 236
- [“Troubleshooting NetApp agents”](#) on page 242

About troubleshooting bundled agents

This chapter describes how to troubleshoot common problems in bundled agents. The chapter lists bundled agent error messages (shown in bold text), and describes the problems associated with each agent. Recommended action is included, where applicable.

This chapter lists most of the error messages associated with the VCS bundled agents. For error messages other than the ones described here, contact Symantec Technical Support.

VCS logging

VCS generates two error message logs: the engine log and the agent log. Log file names are appended by letters. Letter A indicates the first log file, B the second, C the third, and so on.

The agent log is located at %VCS_HOME%\log\agent_A.txt. The format of agent log messages is:

Timestamp (Year/MM/DD) | Mnemonic | Severity | UMI | Agent Type |
Resource Name | Function | Message Text

The agent log message components are defined as follows:

- *Timestamp*: the date and time the message was generated.
- *Mnemonic*: the string ID that represents the product (for example, VCS).
- *Severity*: levels include CRITICAL, ERROR, WARNING, NOTICE, and INFO (most to least severe, respectively).
- *UMI*: a unique message ID.
- *Message Text*: the actual message generated by VCS.

A typical agent log resembles:

```
2004/03/02 16:34:07 VCS WARNING V-16-10051-5008  
NotifierMgr:ntfr:monitor:Expected correct SNMP and | or SMTP  
options
```

Troubleshooting storage agents

Storage agents comprise the Volume Manager Diskgroup agent and MountV agent.

Note: In case of a NetApp storage environment, the Logical Unit Numbers (LUNs) on the NetApp Filer are made highly available by the NetApp Filer and NetApp SnapDrive agents instead of the VMDg and MountV agents respectively. Refer to the application-specific VCS implementation guides for more information on these agents.

Disk Reservation agent error messages

No arguments

This is a VCS internal error.

Recommended Action: Contact Symantec Technical Support.

Insufficient arguments

This is a VCS internal error.

Recommended Action: Contact Symantec Technical Support.

Insufficient memory

This is a VCS internal error.

Recommended Action: Close applications not in use and check memory usage. Contact Symantec Technical Support if the problem persists.

Invalid signature(s) specified. One of the invalid signature is :*signature*

Invalid disk signature specified in the configuration

Recommended Action: Verify the Signature attribute defined in the configuration file is assigned a correct value.

Signature(s) not specified

No value specified for the Signature attribute.

Recommended Action: Verify the Signature attribute defined in the configuration file is assigned a value.

Duplicate signature(s) specified

Duplicate values specified for the Signature attribute.

Recommended Action: Verify the Signature attribute defined in the configuration file is assigned a unique value.

Invalid ConfigPercentage specified

Invalid value specified for the ConfigPercentage attribute.

Recommended Action: Verify the value specified for ConfigPercentage attribute ranges between 51 and 100.

Insufficient memory to store the ConfigPercentage

This is a VCS internal error.

Recommended Action: Contact Symantec Technical Support.

Insufficient memory to store the FailFastInterval

This is a VCS internal error.

Recommended Action: Contact Symantec Technical Support.

Insufficient memory to store the GracePeriod

This is a VCS internal error.

Recommended Action: Contact Symantec Technical Support.

Invalid ConfigPercentage specified. Setting it to the default value (default_percentage)

The value specified for the attribute ConfigPercentage is less than the minimum value, 51. The agent will set the value to 80, which is the default value.

Invalid GracePeriod specified. Setting it to the default value (default_grace_period)

The value specified for the attribute GracePeriod is invalid. The agent will set the value to 5, which is the default value.

VCS Disk reservation driver is not running

This is a VCS internal error.

Recommended Action: Contact Symantec Technical Support.

DiskRes agent has lost the majority.(Acquired = *percentage* Configured = *percentage*)

The agent could not acquire reservation to the number of disks equalling the percentage set in the attribute ConfigPercentage.

Failed to release the disk (Signature = *disk_signature*). Windows error code: *Error_code*

The agent failed to release the disk with the specified signature.

Recommended Action: See the corresponding error code for more information. Contact Symantec Technical Support if the problem persists.

Could not connect to the local node. Error : *Error_code*

This is a VCS internal error.

Recommended Action: Contact Symantec Technical Support.

Insufficient memory to store disk ids. Error : *Error_code*

This is a VCS internal error.

Recommended Action: Contact Symantec Technical Support.

Failed to get the disk list. Error : *Error_code*

This is a VCS internal error.

Recommended Action: Contact Symantec Technical Support.

Failed to get the Port number and Path ID for disk *disk_signature*. Error : *Error_code*

This is a VCS internal error.

Recommended Action: Contact Symantec Technical Support.

Failed to reset the Port *port_no* (Path ID *path*) for disk *disk_signature*. Error : *Error_code*

This is a VCS internal error.

Recommended Action: Contact Symantec Technical Support.

Failed to reset the disk(s). Error : *Error_code*

The agent failed to reset the SCSI disk path. An I/O error or the driver DiskRes.Sys is not running.

Recommended Action: Verify that the driver DiskRes.Sys is located at %WINDIR%\System32\Drivers. Verify that the disk is accessible. See the corresponding error code for more information. Contact Symantec Technical Support if the problem persists.

Failed to create the disk information. Error : *Error_code*

This is a VCS internal error.

Recommended Action: Contact Symantec Technical Support.

Failed to rescan the devices. Error : *Error_code*

This is a VCS internal error.

Recommended Action: Contact Symantec Technical Support.

Failed to create the disk information even after rescan. Error : *Error_code*

This is a VCS internal error.

Recommended Action: Contact Symantec Technical Support.

Failed to reserve *number_of_disks* disk(s) out of *number_of_disks* disk(s) configured.

Error: *Error_code*

The agent failed to reserve the specified number of disks out of the total configured disks.

Recommended Action: Verify the configuration definition of the agent. Verify that no other system holds reservation to the disk. Make sure that the driver DiskRes.Sys is located at %WINDIR%\System32\Drivers.

Failed to release *number_of_disks* disk(s) out of all disks configured.

Error: *Error_code*

The agent failed to release the specified number of disks out of the total configured disks.

Recommended Action: Verify the configuration definition of the agent. Make sure that the driver DiskRes.Sys is located at %WINDIR%\System32\Drivers.

Failed to release *number_of_disks* disk(s) out of *number_of_disks* disks configured.

Error: *Error_code*

The agent failed to release the specified number of disks out of the total configured disks.

Recommended Action: Verify the configuration definition of the agent. Make sure that the driver DiskRes.Sys is located at %WINDIR%\System32\Drivers.

Failed to create the disk information. Windows error code: *Error_code*

This is a VCS internal error.

Recommended Action: Contact Symantec Technical Support.

Percentage disk(s)- *number_of_disks* out of *number_of_disks* disks configured are still persistently reserved. The resource cannot failover.

The specified number of disks are reserved on the node where the DiskRes resource is online. The resource cannot failover to another node.

Failed to get the disk count. Error : *Error_code*

This is a VCS internal error.

Recommended Action: Contact Symantec Technical Support.

Failed to stop the driver. Error : *Error_code*

This is a VCS internal error.

Recommended Action: Contact Symantec Technical Support.

The agent is shutting down but there are still *no_of_disks* disk(s) under persistent reservation.

Some disks are still persistently reserved by the DiskRes resource while the agent is shutting down.

Error occurred while getting the disk reservation cache information. Error *Error_code*

This is a VCS internal error.

Recommended Action: Contact Symantec Technical Support.

Could not collect the cache information for disk *disk_no*. Error : *Error_code*

This is a VCS internal error.

Recommended Action: Contact Symantec Technical Support.

Failed update the cache information. Error: *Error_code*

This is a VCS internal error.

Recommended Action: Contact Symantec Technical Support.

DiskCache information :: %s failed for disk *disk_signature*. Error: *Error_code*

This is a VCS internal error.

Recommended Action: Contact Symantec Technical Support.

Mount agent error messages

Unable to get the arguments

This is a VCS internal error.

Recommended Action: Contact Symantec Technical Support.

Drive path not specified

Incorrect or no value specified for the MountPath attribute.

Recommended Action: Verify that the configuration definition for the MountPath attribute specifies the correct mount path.

Partition number not specified

Incorrect or no value specified for the PartitionNo attribute.

Recommended Action: Verify that the configuration definition for the PartitionNo attribute specifies the correct partition number.

Drive signature not specified

Incorrect or no value specified for the Signature attribute.

Recommended Action: Verify that the configuration definition for the Signature attribute specifies the correct disk signature.

Invalid disk signature (*disk_signature*) specified

Incorrect value specified for the Signature attribute.

Recommended Action: Verify that the configuration definition for the Signature attribute specifies the correct disk signature.

Invalid Child mount path specified

Incorrect value specified for the MountResName attribute.

Recommended Action: Verify that the configuration definition for the MountResName attribute specifies the correct resource name.

Invalid disk (*disk_no*) or partition(*partiton_no*) number specified. Error : *Error_code*

Invalid values specified for disk signature or partition number.

Recommended Action: See the corresponding error code for more information.

Cannot find the disk (*disk_no*) with signature *disk_signature* in the system. Error : *Error_code*

The agent cannot find the specified disk with the given signature.

Recommended Action: See the corresponding error code for more information.

The specified disk (*disk_no*) with signature *disk_signature* is a dynamic disk.

Error : *Error_code*

The specified disk signature belongs to a dynamic disk, which is not supported by the agent.

Recommended Action: Verify that all disks configured using the Mount agent are basic disks. Verify the correct disk signatures are specified in the configuration definition of the agent. To configure dynamic disks, use the MountV agent.

Could not find the type of the child mount *mount_path*. Error : *Error_code*

The agent could not find the specified child mount

Recommended Action: Verify the configuration definition for the specified child mount. Make sure the specified mount exists.

Child mount *mount_path* is not a drive letter. Only one of level dependency is specified by the Mount agent. Mount resource at bottom should be a drive letter mount.

The agent is unable to resolve the specified drive letter.

Recommended Action: Verify the value specified for the MountResName attribute does not have another dependency of a mount path.

Could not find the type of the mount *mount_path*. Error : *Error_code*

This is a VCS internal error.

Recommended Action: Contact Symantec Technical Support.

Failed to check whether the drive letter *drive_letter* is assigned or not. Error : *Error_code*

This is a VCS internal error.

Recommended Action: Contact Symantec Technical Support.

The specified drive letter *drive_letter* is a system drive.

Recommended Action: Specify a drive path other than the one for the system drive.

Child mount resource is not specified or configured

Incorrect value specified for the MountResName attribute.

Recommended Action: Verify that the configuration definition for the MountResName attribute specifies the correct resource name.

Invalid folder mount path (*mount_path*) specified

Recommended Action: Verify the value specified for folder mount is correct.

Invalid mount.

This is a VCS internal error.

Recommended Action: Contact Symantec Technical Support.

Failed to gather Volumes Information on the system. Error : *Error_code*

This is a VCS internal error.

Recommended Action: Contact Symantec Technical Support.

Failed to create the Volume object for DiskNo = *disk_no*, PartitionNo = *partition_no*.

Error : *Error_code*

This is a VCS internal error.

Recommended Action: Contact Symantec Technical Support.

Failed to get the Volume name for DiskNo = *disk_no*, PartitionNo = *partition_no*.

Error : *Error_code*

This is a VCS internal error.

Recommended Action: Contact Symantec Technical Support.

Failed to gather folder mount information for all the volumes. Error : *Error_code*. Volumes information could be incomplete.

This is a VCS internal error.

Recommended Action: Contact Symantec Technical Support.

Failed to find the Volume for Volume Name = *volume_name*. Error : *Error_code*. Volumes information could be incomplete.

This is a VCS internal error.

Recommended Action: Contact Symantec Technical Support.

Failed to find the folder mount information for Volume Name = *volume_name*.

Error : *Error_code*. Volumes information could be incomplete.

This is a VCS internal error.

Recommended Action: Contact Symantec Technical Support.

There *is/are* folder mount(s) mounted on the same drive. Folder mount = *folder_mount*.

Error : *Error_code*. Volumes information could be incomplete.

More than one folders are mounted on the same drive.

Recommended Action: Make sure no additional folders are mounted on the specified drive.

The configured Volume is also mounted as a drive letter. Failed to get the Drive letter.

Error : *Error_code*

Recommended Action: Unmount the volume or specify another volume information.

The configured Volume is also mounted as a drive letter *drive_letter*.

Recommended Action: Unmount the volume or specify another volume information.

Validate disk partition failed. Error : *Error_code*

This is a VCS internal error.

Recommended Action: Contact Symantec Technical Support.

Could not find the Disk with number *disk_no*. Error : *Error_code*

This is a VCS internal error.

Recommended Action: Contact Symantec Technical Support.

**Unable to lock the volume. Disk No. = *disk_no*, PartitionNo = *partition_no*.
Error : *Error_code***

The agent could not lock the volume while dismounting, indicating a potential hardware error or that other applications are accessing the volume.

Recommended Action: Verify that no other applications, including Windows Explorer, are accessing the volume. Verify the installed disk and the configured partition. Set the ListApplications attribute to 1 to obtain a list of applications that are accessing the volume.

**Failed to unlock the volume. Disk No. = *disk_no*, PartitionNo =*partition_no*.
Error : *Error_code***

The agent could not unlock the volume while dismounting, indicating a potential hardware error or that other applications are accessing the volume.

Recommended Action: Ensure that no other applications, including Windows Explorer, are accessing the volume. Verify the installed disk and the configured partition. Contact Symantec Technical Support if the problem persists.

**Failed to mount the volume. Disk No. = *disk_no*, PartitionNo =*partition_no*.
Error : *Error_code***

This is a VCS internal error.

Recommended Action: Contact Symantec Technical Support.

**Failed to dismount the volume. Disk No. = *disk_no*, PartitionNo =*partition_no*.
Error : *Error_code***

This is a VCS internal error.

Recommended Action: Contact Symantec Technical Support.

**Could not access the volume. Disk No. = *disk_no*, PartitionNo = *partition_no*
 Mount Path = *Mount_path*. Error : *Error_code***

The specified device path is inaccessible, indicating a potential hardware error.

Recommended Action: Verify the installed disk and the configured partition. Also make sure no other application is accessing the volume. Set the ListApplications attribute to 1 to obtain a list of applications that are accessing the volume.

**Failed to unmount the volume. Disk No. = *disk_no*, PartitionNo = *partition_no*
 Mount Path = *Mount_path*. Error : *Error_code***

This is a VCS internal error.

Recommended Action: Contact Symantec Technical Support.

**File system is dirty. Cannot online the resource. Unmounting the volume.
 Error : *Error_code***

The filesystem at the specified driver letter or mount path is not clean.

Recommended Action: Set the AutoFSClean to 1 if you want the agent to clean the filesystem. Otherwise, clean the filesystem manually.

Drive letter *drive_letter* is not assigned Exit code : *Exit_code*

This is a VCS internal error.

Recommended Action: Contact Symantec Technical Support.

Failed to flush the Volume. Error : *Error_code*

This is a VCS internal error.

Recommended Action: Contact Symantec Technical Support.

Failed to get the application log information. Error : *Error_code*

The agent could not find the name of the application accessing the volume.

Recommended Action: See the corresponding error code for more information. Contact Symantec Technical Support if the problem persists.

Volumes information mismatched. Name1 = *vol1_name*, Name2 = *vol2_name*

This is a VCS internal error.

Recommended Action: Contact Symantec Technical Support.

Unable to unmount the volume so cannot failover.

This is a VCS internal error.

Recommended Action: Contact Symantec Technical Support.

Failed to add the administrative share. Error : *Error_code*

The agent could not assign the default administrative share for the configured drive letter.

Recommended Action: Verify that no administrative share for the drive letter exists.

Failed to delete the administrative share. Error : *Error_code*

The agent could not remove the administrative share assigned during the online operation.

Check disk failed. Cannot say properly online so unmounting the volume. Error : *Error_code*

This is a VCS internal error.

Recommended Action: Contact Symantec Technical Support.

Failed to check whether the file system is dirty. Cannot online the resource. Unmounting the volume. Error : *Error_code*

This is a VCS internal error.

Recommended Action: Contact Symantec Technical Support.

The volume is already mounted as *drive_letter* (drive letter). Please correct the mount path. Error : *Error_code*

The target volume is mounted as a directory on an NTFS folder. The Mount agent does not support this configuration.

Please check whether the specified mount path is a removable media or network drive.

Recommended Action: Make sure the specified mount path is not a removable media or a network drive.

Unable to unmount the volume as there are applications that are still using the volume for WRITE. Please set ListApplication attribute to 1(if not set) to log the application names

The specified volume is being accessed by other applications.

Recommended Action: Set the ListApplications attribute to 1 to obtain a list of applications that are accessing the volume.

The volume (*vol_name*) is unmounted unexpectedly.

This is a VCS internal error.

Recommended Action: Contact Symantec Technical Support.

The base volume (*vol_name*) is not a NTFS volume

The specified mount point for the volume does not reside on an NTFS-formatted volume.

Recommended Action: Reset the attribute MountPath to point to an NTFS-formatted volume.

Mount path *Mount_path* does not exist

Invalid or incorrect mount path specified for the MountPath attribute.

Recommended Action: Verify that the configuration definition for the MountPath attribute specifies the correct mount path.

Failed to find the volume (*vol_name*) in the list. Error : *Error_code*

This is a VCS internal error.

Recommended Action: Contact Symantec Technical Support.

Failed to find whether the base volume (*vol_name*) is NTFS or not. Error : *Error_code*

This is a VCS internal error.

Recommended Action: Contact Symantec Technical Support.

Failed to get the volume name(GUID) for *guid*. Error : *Error_code*

This is a VCS internal error.

Recommended Action: Contact Symantec Technical Support.

Error occurred while getting the drive letter(*drive_letter*) information.

This is a VCS internal error.

Recommended Action: Contact Symantec Technical Support.

Volume Manager (VMDg) agent error messages

The Agent is shutting down the system because it is configured so or it failed to start VxVM Service.

The VMDg agent is shutting down your system because you have provided SHUTDOWN as a value for VxVMFailAction attribute. This action is taken when the VMDg agent attempts to restart the Veritas Storage Agent service for the number of times specified in VxVMRestartAttempts attribute.

Cluster Server license is not enabled in Volume Manager.

Storage Foundation for Windows was not installed with the HA license.
Recommended Action: Contact Symantec Technical Support.

Diskgroup not configured

No value specified for the DiskGroupName attribute.
Recommended Action: Verify the DiskGroupName attribute defined in the configuration file is assigned a value.

Could not initialize Volume Manager connection. Error = *Error_code*

The Veritas Enterprise Administrator Service is either not in a running state or is not responding to service request.
Recommended Action: Verify that the service is in a running state.

Could not get SCM handle [*Error Type:Error Code*]

The agent could not open a handle to the Service Control Manager.
Recommended Action: See the error type and error code for more information. Contact Symantec Technical Support if the problem persists.

Online diskgroup. Less than half of total disks available in the diskgroup.

Less than half the disks are available in the disk group.
Recommended Action: For the ForceImport to work, make sure at least 50% of the disks are available.

Online diskgroup : *Error_description*

The agent failed to bring the disk group online.
Recommended Action: See the corresponding error description for more information.

Offline diskgroup : *Error_description*

The agent failed to bring the disk group offline.

Recommended Action: See the corresponding error description for more information.

Init diskgroup : *Error_description*

The agent failed to initialize the disk group.

Recommended Action: See the corresponding error description for more information.

Failed to start VxOb Service (Error = *Error Type:Error Code*)

The agent failed to start the VxOb service.

Recommended Action: Try to start the VxOb service manually. See the corresponding error type and error code for more information.

Failed to query VxOb (Error = *Error Type:Error Code*)

The agent failed to query VxOb.

Recommended Action: Try to query VxOb manually. See the corresponding error type and error code for more information.

Failed to open VxOb (Error = *Error Type:Error Code*)

The agent failed to open VxOb.

Recommended Action: Try to open VxOb manually. See the corresponding error type and error code for more information.

Query imported cluster diskgroups : *Error_description*

Recommended Action: See the corresponding error description for more information.

Query SCSI Reservation : *Error_description*

Recommended Action: See the corresponding error description for more information.

One or more disks in this diskgroup are unsteady

One or more disks or volumes in the disk group are not in a healthy state.

Recommended Action: View the disks using the Veritas Enterprise Administrator console and verify the state of the disks.

Disk availability check : *Error_description*

Recommended Action: See the corresponding error description for more information.

Init diskgroup failed : The diskgroup and GUID do not match

Recommended Action: Use the `vmgetdrive -details` command to find the correct GUID.

MountV agent error messages

Could not initialize Volume Manager connection. Error = *Error_code*

The Veritas Enterprise Administrator Service is either not in a running state or is not responding to service request.

Recommended Action: Verify that the service is in a running state.

Cluster Server license is not enabled in Volume Manager.

Storage Foundation for Windows was not installed with the HA license.

Recommended Action: Contact Symantec Technical Support.

***Attribute_name* not configured**

No value provided for the specified attribute.

Recommended Action: Verify the specified attribute defined in the configuration file is assigned a value.

Failed to get volume properties [*Error_type*:*Error_code*]

The agent failed to get the properties of the configured volume.

Recommended Action: See the corresponding error type and error code for more information.

Volume *folder_mount_path* is also mounted as Driveletter *drive_letter*

The specified volume is already mounted. The agent does not allow a volume to be mounted on multiple drives.

Recommended Action: Verify that the volume is not mounted at another drive letter. Also check that the volume is not mounted as an NTFS mount point.

Volume *drive_letter* is also mounted as NTFS Folder mount(s) at *folder_mount_path*

The agent does not allow a volume to be mounted on multiple drives.

Recommended Action: Verify that the volume is not mounted at a drive letter. Also check that the volume is not mounted as an NTFS mount point.

Volume *drive_letter* is Mounted as *mount_path* but configured as *volume_name*

The mount path for the volume specified in the configuration file is different from the actual mount path.

Recommended Action: Verify the mount path specified in the configuration file is correct.

Volume *volume_name* is already mounted as NTFS Folder *folder_mount_path*

The agent does not allow a volume to be mounted on multiple drives.

Recommended Action: Verify that the volume is not mounted at a drive letter. Also check that the volume is not mounted as an NTFS mount point.

Volume *volume_name* has been mounted multiple times (*no_of_times*)

The agent does not allow a volume to be mounted on multiple drives.

Recommended Action: Verify that the volume is not mounted at a drive letter. Also check that the volume is not mounted as an NTFS mount point.

Volume *volume_name* has also been mounted as (*drive_letter*)

The agent does not allow a volume to be mounted on multiple drives.

Recommended Action: Verify that the volume is not mounted at a drive letter. Also check that the volume is not mounted as an NTFS mount point.

Diskgroup not present

The specified disk group is not present on the system.

Recommended Action: Verify that the disk group exists on the system.

Volume not present

The specified volume is not present on the system.

Recommended Action: Verify that the volume exists on the system.

Connection to VM not initialized

The Veritas Enterprise Administrator Service is either not in a running state or is not responding to service request.

Recommended Action: Verify that the service is in a running state.

Mount_path is not suitable for folder mount [Error_type:Error_code]

The specified MountPath is not suitable for a folder mount.

Recommended Action: See the description for the MountPath attribute for the VMDg agent. See the corresponding error type and error code for more information.

Mount_path is not on an NTFS formatted volume

The specified MountPath is not an NTFS formatted volume.

Failed to unlock volume [Error_type:Error_code]

The agent could not unlock the volume while dismounting, indicating a potential hardware error or that other applications are accessing the volume.

Recommended Action: Ensure that no other applications, including Windows Explorer, are accessing the volume. Verify the installed disk and the configured partition. Contact Symantec Technical Support if the problem persists.

Failed to lock volume [Error_type:Error_code]

The agent could not lock the volume while dismounting, indicating a potential hardware error or that other applications are accessing the volume.

Recommended Action: Verify that no other applications, including Windows Explorer, are accessing the volume. Verify the installed disk and the configured partition. Set the ListApplications attribute to 1 to obtain a list of applications that are accessing the volume.

Filesystem at drive_letter/mount_path is not clean [Error_type:Error_code]

The file system at the specified drive letter or mount path is not clean

Recommended Action: Set the AutoFSClean to 1 if you want the agent to clean the filesystem. Otherwise, clean the filesystem manually.

Failed to add administrative share

The agent could not assign the default administrative share. An administrative share is already added for this volume.

Failed to delete administrative share [*Error_type:Error_code*]

The agent could not remove the administrative share assigned during the online operation.

Recommended Action: See the corresponding error type and error code for more information.

Troubleshooting network agents

Network agents comprise the NIC agent, IP agent, and Lanman agent.

NIC agent error messages

Initialization failed

The agent failed to retrieve network information. This is a VCS internal error.

Recommended Action: Contact Symantec Technical Support.

Invalid MAC Address format

Incorrect format for MAC Address specified in the MACAddress attribute.

Recommended Action: Verify the MAC Address is in the format AA-BB-CC-DD.

Invalid MAC Address (*MAC_Address*) specified.

Invalid value specified for adapters physical address.

Recommended Action: Verify the MACAddress attribute defined in the configuration file is assigned a value.

Adapter (*Adapter_Name*) Connection status cannot be found

The agent failed to retrieve the connection status of the NIC.

Recommended Action: Contact Symantec Technical Support.

PingHostList not specified

No value is specified for PingHostList attribute even though the UseConnectionStatus is set to False.

Recommended Action: Specify a value for PingHostList.

UDP echo attempt failed

This is a network error.

Recommended Action: Contact Symantec Technical Support.

UDP check failed

This is a network error.

Recommended Action: Contact Symantec Technical Support.

Failed to clear all IPs from adapter *Adapter_Name*

The agent failed to deallocate all IPs assigned to a network card. The agent does so to avoid IP conflict.

Recommended Action: Contact Symantec Technical Support

Adapter (*Adapter_Name*) not found

The agent could not detect the specified adapter.

Recommended Action: Verify the MACAddress attribute defined in the configuration file is assigned a value.

Adapter (*Adapter_Name*) is not connected

The adapter specified in the MACAddress attribute is not available on the network.

Recommended Action: Check the network connections. If the problem persists, verify the MACAddress attribute defined in the configuration file is assigned a value.

Failed to get IFEntry for adapter *Adapter_Name*

The agent failed to retrieve an entry for the specified adapter from the IF table. This is a VCS internal error.

Recommended Action: Contact Symantec Technical Support.

TCP/IP is not enabled for adapter (*Adapter_Name*)

TCP/IP is not enabled for the specified adapter.

Recommended Action: Enable TCP/IP for the adapter.

Error percentage exceeded for (*Adapter_name*)

The adapter has exceeded the error percentage for sending packets, specified in the MaxTxErrorPercentage attribute.

Recommended Action: Contact Symantec Technical Support.

Error percentage exceeded limit

The adapter has exceeded the error percentage, specified by MaxTxErrorPercentage, by the number of times specified in MaxTxErrInterval attribute.

Recommended Action: Contact Symantec Technical Support.

IP agent error messages

Initialization failed

The agent failed to retrieve network information. This is a VCS internal error.

Recommended Action: Contact Symantec Technical Support.

Invalid attributes

Invalid values specified for the agent attributes.

Recommended Action: Verify the attributes defined in the configuration file are assigned a correct value.

Invalid MacAddress format

Incorrect format for MAC Address specified in the MACAddress attribute.

Recommended Action: Verify the MAC Address is in the format AA-BB-CC-DD.

Invalid IP format

Incorrect format for IP address specified in the Address attribute.

Recommended Action: Verify the IP address is in the correct format.

Ping failed for IP (*IP_Address*)

The agent failed to ping the specified IP address.

Recommended Action: Verify the specified IP address exists in the network. Check the network connections if the problem persists.

Host *IP_Address* already exists

The specified IP address already exists in the network

Recommended Action: Verify the value specified for Address attribute is unique.

IP (*IP_Address*) is Admin IP

The specified virtual IP is the base ID for a NIC in the network.

Recommended Action: Specify a unique IP address.

Incorrect IP (*IP_Address*)

Invalid value specified for the Address attribute.

Recommended Action: Verify the Address attribute defined in the configuration file is assigned a correct value.

Incorrect subnet mask (*SubNet_Mask*)

Invalid value specified for the SubNetMask attribute.

Recommended Action: Verify the SubNetMask attribute defined in the configuration file is assigned a correct value.

Adapter (*IP_Address*) not found

The agent could not detect the specified adapter in the network.

Recommended Action: Verify the Address attribute defined in the configuration file is assigned a correct value.

DHCP is enabled on Adapter (*IP_Address*)

DHCP is enabled on the specified adapter.

Recommended Action: Disable DHCP and specify an IP address for the adapter.

Invalid Adapter (*IP_Address*)

Invalid value specified for the Address attribute.

Recommended Action: Verify the Address attribute defined in the configuration file is assigned a correct value.

Invalid MacAddress (*MAC_Address*) specified

Invalid value specified for the MACAddress attribute.

Recommended Action: Verify the MACAddress attribute defined in the configuration file is assigned a correct value.

TCP/IP is not enabled for adapter (*Adapter_Name*)

TCP/IP is not enabled for the specified adapter.

Recommended Action: Enable TCP/IP for the adapter.

Lanman agent error messages

Virtual server name specified in the configuration is invalid (*Virtual Server Name*)

The virtual server name exceeds the limit of 16 characters, or it contains invalid characters.

Recommended Action: Verify that the NetBios name is less than sixteen characters, and that it does not contain any of the following characters:
/\:.*?"<>|=.

Virtual name already exists in the network

The specified virtual name already exists in the network.

Recommended Action: Verify the VirtualName attribute defined in the configuration file is assigned a unique value.

Failed to update DNS entry (error_type: *Error Type*, error_code: *Error Code*)

The agent failed to update the DNS entry.

Recommended Action: Verify the DNS server is alive, and the reverse lookup zone is configured.

Failed to update Computer account in Active directory (error_type: *Error Type*, error_code: *Error Code*)

The agent failed to add the computer account to the Active Directory.

Recommended Action: Verify whether the user, in whose context the Veritas Helper Service runs, has the required permissions.

Failed to register Virtual server name to Netbios (error_type: *Error type*, error_code: *Error Code*)

The agent failed to register the virtual server name with the NetBios.

Recommended Action: Verify whether the virtual name is already configured. Run nbtstat - n to check NetBios bindings. Contact Symantec Technical Support if the problem persists.

Failed to start the 'Veritas Cluster Server Helper' service. (error_type: *Error Type*, error_code: *Error Code*)

The agent failed to start the specified service.

Recommended Action: Verify whether the service is installed on the node. Also verify whether the user, in whose context the service will run, has the required permissions.

IP address specified for MultiNetInfo is invalid (entry=*IP Address*)

Invalid IP address specified in the MultiNetInfo attribute.

Recommended Action: Verify the MultiNetInfo attribute defined in the configuration file is assigned correct values.

SubnetMask specified for MultiNetInfo is invalid (entry=*subnet_mask*)

Invalid subnet mask specified in the MultiNetInfo attribute.

Recommended Action: Verify the MultiNetInfo attribute defined in the configuration file is assigned correct values.

WINS address specified for MultinetInfo is invalid (entry=*wins_address*)

Invalid WINS address specified in the MultiNetInfo attribute.

Recommended Action: Verify the MultiNetInfo attribute defined in the configuration file is assigned correct values.

VirtualName attribute is not specified in the configuration

No value specified for VirtualName attribute.

Recommended Action: Verify the VirtualName attribute defined in the configuration file is assigned a value.

IP address specified in the configuration is invalid

Invalid value specified for the IP address.

Recommended Action: Verify the value specified for the IP address is valid.

SubnetMask specified in the configuration is invalid

Invalid value specified for the subnet mask.

Recommended Action: Verify the value specified for the subnet mask is valid.

MultinetInfo attribute specified in the configuration is in invalid format

The value specified for MultiNetInfo attribute is not in the standard format.

Recommended Action: Verify the format for the MultiNetInfo attribute.

There are no valid IP addresses specified in the configuration

All the IP addresses specified in the configuration are invalid.

Recommended Action: Verify the IP addresses specified in the configuration file.

IP address specified in the configuration is not online. (ip= IP Address)

The specified IP address is not online in the cluster.

Recommended Action: Verify the specified IP address exists in the network.

Mismatch in the subnet mask specified in configuration and the actual subnet mask configured for the adapter

The subnet mask specified in the configuration file does not match with the subnet mask for the configured adapter.

Recommended Action: Verify the subnet mask specified in the MultiNetInfo attribute is correct.

WINS address specified in the configuration is not found in the adapter's WINS address list

The specified WINS address does not exist in the WINS address list of the adapter.

Recommended Action: Verify the WINS address specified in the MultiNetInfo attribute is correct.

Attempt to start 'Veritas Cluster Server Helper' service has failed. (error_type: Error Type, error_code: Error Code)

The agent failed to start the specified service.

Recommended Action: Verify whether the service is installed on the node. Also verify whether the user, in whose context the service will run, has the required permissions.

Attempt to stop 'Veritas Cluster Server Helper' service has failed. (error_type: Error Type, error_code: Error Code)

The agent failed to stop the specified service.

Recommended Action: Verify whether the service is installed on the node. Also verify whether the user, in whose context the service will run, has the required permissions.

Attempt to online the Lanman resource has failed. (error_type: *Error Type*, error_code: *Error Code*)

The agent failed to online the Lanman resource. This is a VCS internal error.

Recommended Action: See the Windows error code for more information. Contact Symantec Technical Support if the problem persists.

V-16-10051-3051 No DNS servers IPv6 address found. Cannot update DNS. Please provide IPv6 addresses for the DNS servers either on the NIC or the Lanman configuration.

This error is specific to an IPv6 environment. The Lanman agent has failed to update the virtual IPv6 address entry in the DNS records as the DNS server details are not specified.

The Lanman resource itself is able to come online, but other resources in the service group that depend on the Lanman resource (FileShare for example) may fail to come online as the virtual server name that uses an IPv6 address is not updated in the DNS.

In an IPv6 environment, the Lanman agent relies on the DNS records to validate the server name on the network.

Recommended Action: If the virtual IP is an IPv6 address then you must specify the DNS server details, either in the network adapter properties or in the Lanman agent's AdditionalDNSServers attribute.

Troubleshooting FileShare agents

FileShare agents comprise the FileShare agent and the CompositeFileShare agent.

FileShare agent error messages

Attribute value(s) invalid for *attr_name*

The specified attribute name has invalid value.

Recommended Action: Verify the configuration file and make sure the correct attribute value is specified.

Failed to open folder *folder_name* [ErrorType:Error Code]

The agent failed to open the folder specified in the ShareName attribute.

Recommended Action: Verify whether the specified folder exists. Check the permissions for the folder.

Folder *folder_name* (\\system_name\share_name) already shared

The specified folder name is already shared.

Recommended Action: Verify the configuration file for the specified ShareName.

Failed to share folder *folder_name* as (\\system_name\share_name) [ErrorType:Error Code]

The agent failed to share the specified folder.

Recommended Action: Verify the configuration file for the specified ShareName.

MaxUsers for share *share_name* is less than configured

The number of users authorized to access a share is less than the number of users specified in the MaxUsers attribute.

Recommended Action: Make sure the number of users authorized to access a share and the number of users specified in the MaxUsers attribute is same.

Failed to unshare folder *folder_name* as (\\system_name\share_name) [ErrorType:Error Code]

The agent failed to unshare the specified folder.

Recommended Action: Verify the configuration file for the specified share name.

Path mismatch for share *share_name*

The specified path name is already shared.

Recommended Action: Verify that the share name does not already exist on the network. If the share does not exist, contact Symantec Technical Support.

System error occurred for folder *folder_name* Error [*Error_code*]

Recommended Action: See the Windows error code for more information. Contact Symantec Technical Support if the problem persists.

FileShare Error : The Server service is not available

The agent requires the Server service to be started before it can bring the resource online.

Recommended Action: Verify that the Server service is running properly.

Permissions error occurred for folder *folder_name* Error [*error_id*]

Recommended Action: See the corresponding *error_id* for more information. Error ID 6 denotes a mismatch in the configured permission and the actual permission for the folder share. Error ID 7 denotes an error while matching the configured permission and actual permission for the share.

Share name *share_name* contains invalid characters

The specified share name contains invalid characters.

Recommended Action: Make sure the specified share name does not contain special characters (\, /, :, *, ?, <, >, |).

CompositeFileShare agent error messages

Attribute value(s) invalid for *attr_name*

The specified attribute name has an invalid value.

Recommended Action: Verify the configuration file and make sure the correct attribute value is specified.

Failed to open folder *folder_name* [ErrorType:Error Code]

The agent failed to open the folder specified in the ShareName attribute.

Recommended Action: Verify whether the specified folder exists. Check the permissions for the folder.

Folder *folder_name* (\\system_name\share_name) already shared

The specified folder name is already shared.

Recommended Action: Verify the configuration file for the specified ShareName.

Failed to share folder *folder_name* as (\\system_name\share_name) [ErrorType:Error Code]

The agent failed to share the specified folder.

Recommended Action: Verify the configuration file for the specified ShareName.

MaxUsers for share *share_name* is less than configured

The number of users authorized to access a share is less than the number of users specified in the MaxUsers attribute.

Recommended Action: Make sure the number of users authorized to access a share and the number of users specified in the MaxUsers attribute is same.

Failed to unshare folder *folder_name* as (\\system_name\share_name) [ErrorType:Error Code]

The agent failed to unshare the specified folder.

Recommended Action: Verify the configuration file for the specified share name.

Path mismatch for share *share_name*

The specified path name is already shared.

Recommended Action: Verify that the share name does not already exist on the network. If the share does not exist, contact Symantec Technical Support.

Composite FileShare Error : The Server service is not available

The agent requires the Server service to be started before it can bring the resource online.

Recommended Action: Verify that the Server service is running properly.

Permissions error occurred for folder *folder_name* Error [*error_id*]

Recommended Action: See the corresponding *error_id* for more information. Error ID 6 denotes a mismatch in the configured permission and the actual permission for the folder share. Error ID 7 denotes an error while matching the configured permission and actual permission for the share.

Share name *share_name* contains invalid characters

The specified share name contains invalid characters.

Recommended Action: Make sure the specified share name does not contain special characters (\, /, :, *, ?, <, >, |).

Troubleshooting PrintShare agents

PrintShare agents comprise the PrintSpool agent and the PrintShare agent.

PrintSpool agent error messages

VCS INFO V-16-10051-7047

PrintSpool:<printspoolresourcename>:online:Failed to get the Lanman name '<virtualservername>' from directory. ErrorType=27, Error=0x00000003.

VCS INFO V-16-10051-7049

PrintSpool:<printspoolresourcename>:online:Failed to publish virtual spooler '<virtualservername>' in directory

This error indicates that the agent was unable to find the print share virtual name (Lanman) in the AD. This error may occur when PrintShare service group is set up in a disaster recovery (DR) environment. When you modify the printshare service to add a printer and then switch the service group to the remote site, the printspool resource in the service group may fault with these errors.

Recommended Action: Set the OnlineRetryLimit attribute value of the printspool resource to 2. The PrintSpool agent makes two attempts to bring the resource online. In most cases, the 2nd attempt is successful.

LanmanResName attribute has not been configured.

No value specified for the LanmanResName attribute.

Recommended Action: Verify the LanmanResName attribute defined in the configuration file is assigned a value.

IPResName attribute has not been configured.

No value specified for the IPResName attribute.

Recommended Action: Verify the IPResName attribute defined in the configuration file is assigned a value.

MountResName attribute has not been configured.

No value specified for the MountResName attribute.

Recommended Action: Verify the MountResName attribute defined in the configuration file is assigned a value.

SpoolDirectory attribute has not been configured.

No value specified for the SpoolDir attribute.

Recommended Action: Verify the SpoolDir attribute defined in the configuration file is assigned a value.

The spooler path '*spooler_path*' is not valid.

Invalid spooler path specified in the SpoolDir attribute.

Recommended Action: Specify the correct spooler path in the SpoolDir attribute.

Spooler is not running

The agent was not able to detect a running PrintSpooler service.

Recommended Action: Verify that the Spooler service is running properly.

Duplicate Lanman name (*Lanman_name*) provided. Another PrintSpool resource exists with this Lanman name.

The specified Lanman name already exists in the cluster.

Recommended Action: Specify a unique Lanman name in the LanmanResName attribute.

Duplicate IP address (*ip_address*) provided. Another PrintSpool resource exists with this IP.

The specified IP address already exists in the cluster.

Recommended Action: Specify a unique IP address in the IPResName attribute.

Attribute mismatch for Lanman resource. Attribute change is not supported.

The value specified for the Lanman resource was changed manually after the resource was brought online.

Recommended Action: Offline the service group with the PrintSpool resource, disable the PrintSpool resource, and specify the value for LanmanResName attribute. Enable the PrintSpool resource and online the service group.

Attribute mismatch for IP resource. Attribute change is not supported.

The value specified for the IP resource was changed manually after the resource was brought online.

Recommended Action: Offline the service group with the PrintSpool resource, disable the PrintSpool resource, and specify the value for

IPResName attribute. Enable the PrintSpool resource and online the service group.

Failed to online the virtual spooler. Error= *Error Code*.

The agent failed to online the virtual spooler.

Recommended Action: See the Windows error code for more information. Contact Symantec Technical Support if the problem persists.

PrintShare agent error messages

Attribute value(s) invalid for *attr_name*

The specified attribute name has an invalid value.

Recommended Action: Verify the configuration file and make sure the correct attribute value is specified.

Unknown error for printer (*\\system_name\printer_name*) [ErrorType:Error Code]

Recommended Action: See the Windows error code for more information on the error. Contact Symantec Technical Support if the problem persists.

Printer *printer_name* (*\\system_name\printer_name*) already shared

The specified folder name is already shared.

Recommended Action: Verify the configuration file for the specified ShareName.

Failed to share printer *printer_name* as (*\\system_name\printer_name*) [ErrorType:Error Code]

The agent failed to share the specified folder.

Recommended Action: Verify the configuration file for the specified ShareName.

Failed to unshare printer *printer_name* as (*\\system_name\printer_name*) [ErrorType:Error Code]

The agent failed to unshare the specified folder.

Recommended Action: Verify the configuration file for the specified share name.

Printer mismatch for share *share_name*

The specified printer name is already shared.

Recommended Action: Verify that the share name does not already exist on the network. If the share does not exist, contact Symantec Technical Support.

PrintShare Error: The Server service is not available.

The agent requires the Server service to be started before it can bring the resource online.

Recommended Action: Verify that the Server service is running properly.

Share name *share_name* contains invalid characters

The specified share name contains invalid characters.

Recommended Action: Make sure the specified share name does not contain special characters (\, /, :, *, ?, <, >, |).

Troubleshooting services and application agents

Services and application agents comprise GenericService, ServiceMonitor, and Process agent.

IIS agent error messages

Failed to create the IIS services map.

Recommended Action: Verify the SiteType attribute is defined correctly in the configuration. See the associated Windows error type and error code for more information.

Failed to parse the argument list.

The agent could not pass all arguments associated with the agent's resource type definition.

Recommended Action: Verify the configuration definition of the agent.

Failed to allocate memory for IIS Service resource object.

Recommended Action: Verify the system has adequate memory to run IIS and VCS.

Failed to find the service object. Please check the SiteType attribute.

Recommended Action: Verify the configuration definition of the SiteType attribute.

Arguments are not specified correctly, Please check ArgList, ResName

Some attributes associated with the agent are not defined correctly.

Recommended Action: Verify the configuration definition of the specified attribute.

Configuration error. Attribute *attribute* is not configured.

Recommended Action: Verify the configuration definition of the specified attribute.

Error Type. Internal error IP (%s) Failed to convert IP address to ASCII. Error Code

Recommended Action: Verify the configuration definition of the IP resources. See the associated Windows error type and error code for more information.

Failed to start/stop the application pool.

Recommended Action: Verify the name of the application pool is correctly defined in the agent's configuration.

Failed to get the application pool state. Error Type. Error Code.

The agent could not determine the state of the configured application pool.

Recommended Action: Verify the name of the application pool is correctly defined in the agent's configuration. See the associated Windows error type and error code for more information.

Failed to get the IIS virtual directory object *object_name*. Error Type. Error Code.

The agent could not access the specified virtual directory object.

Recommended Action: Verify the virtual directory object for the site exists. See the associated Windows error type and error code for more information.

Failed to start the application pool *poolname*. Error Type. Error Code.

The agent could not start the specified application pool.

Recommended Action: Verify the configuration definition of the application pool.

Failed to get the application pool interface. Error Type. Error Code.

The agent could not access the COM interfaces for the application pool.

Recommended Action: See the associated Windows error type and error code for more information.

Failed to stop the application pool *poolname*. Error Type. Error Code.

The agent could not stop the specified application pool.

Recommended Action: Verify the configuration definition of the application pool.

Failed to start the IIS site/virtual server. *Error Type. Error Code.*

The agent could not start the specified IIS site or virtual server.

Recommended Action: Verify the specified site or server exists and verify its configuration definition.

Failed to stop the IIS site/virtual server. *Error Type. Error Code.*

The agent could not stop the specified IIS site or virtual server.

Recommended Action: Verify configuration definition of the specified site or server.

Failed to determine the state of the IIS site/virtual server. *Error Type. Error Code.*

The agent could not determine the state of the specified IIS site or virtual server.

Recommended Action: Verify configuration definition of the specified site or server.

Failed to get the application pool state and the bind path. *Error Type. Error Code.*

The agent could not determine the state of the specified application pool.

Recommended Action: Verify configuration definition of the specified application pool.

Failed to get the IIS version. *Error Type. Error Code.*

The agent could not retrieve the version information for IIS.

Recommended Action: Verify that a supported IIS version is installed on all nodes in the cluster. See the associated Windows error type and error code for more information.

Failed to get the registry *keyname. Error Type. Error Code.*

The agent could not access the specified registry key.

Recommended Action: Verify the specified registry key exists.

Failed to start service *servicename. Error Type. Error Code.*

The agent could not start the specified service.

Recommended Action: Verify the service exists and is correctly defined in the configuration file. Verify that the service is supported by the host.

Failed to get the state of service *servicename*. Error Type. Error Code.

The agent could not determine the state of the specified service.

Recommended Action: Verify the service exists and is correctly defined in the configuration file. Verify that the service is supported by the host

Failed to stop service *servicename*. Error Type. Error Code.

The agent could not stop the specified service.

Recommended Action: Verify the service exists and is correctly defined in the configuration file. Verify that the service is supported by the host

Failed to initialize service object *servicename*. Error Type. Error Code.

The agent could not initialize the specified service.

Recommended Action: Verify the service exists and is correctly defined in the configuration file. Verify that the service is supported by the host

GenericService agent error messages

VCS ERROR V-16-10051-6012 GenericService:MSOlap-resource name Online:Failed to wait for the service service name to start. Error = 25

This error may occur if the SQL Server 2008 Analysis Service takes a long time to start. The configured GenericService resource may go into an unknown state.

Recommended Action: The GenericService agent attributes DelayAfterOffline and DelayAfterOnline determine the number of seconds the agent waits for the service to start or stop. Modify these attribute values depending on the time the configured service takes to start or stop once the resource is taken online or offline in the environment.

The ServiceName attribute has not been configured

No value specified for the ServiceName attribute.

Recommended Action: Verify the ServiceName attribute defined in the configuration file is assigned a value.

The password attribute has not been configured

No value specified for the Password attribute.

Recommended Action: Verify the Password attribute defined in the configuration file is assigned a value.

Failed to get the password attribute. Error = Error Code

The agent failed to decrypt the specified password.

Recommended Action: Use the vscencrypt utility to get an encrypted password. Specify the encrypted password to the Password attribute in the configuration file.

Failed to convert the password attribute. Error = Error Code

The agent failed to convert the password attribute. This is a VCS internal error.

Recommended Action: Offline and online the service group. Contact Symantec Technical Support if the problem persists.

Failed to allocate memory

The agent failed to allocate the memory. This is a VCS internal error.

Recommended Action: Offline and online the service group. Contact Symantec Technical Support if the problem persists.

Failed to lookup the account name 'Account_Name'. Error = Error Code

The agent failed to obtain the SID for the specified user.

Recommended Action: Verify that the domain controller is accessible, or the specified user exists. See the error code if the problem persists.

Failed to open the SCM handle. Error = Error Code

The agent failed to obtain the SCM handle. This occurs if the specified Service Control Manager (SCM) database does not exist, or the requested access is denied.

Recommended Action: Verify that SCM can be run on the host.

The service 'Service_Name' is not in stopped state

The agent failed to online the service because the service was not in STOPPED state.

Recommended Action: Verify the state of the service and re-issue the online command.

Failed to decrypt the password

The agent failed to decrypt the specified password.

Recommended Action: Verify that it the password is encrypted using the VCS Encrypt utility (described in the *Veritas Cluster Server Administrator's Guide*).

Failed to change the user context of the service '*Service_Name*' to '*DomainNameUsername*'. Error = *Error Code*

The agent failed to change the user context in which the service will run.

Recommended Action: See the Windows error code for further information.

Failed to start the service '*Service_Name*'. Error = *Error Code*

The agent failed to start the specified service.

Recommended Action: Verify the binaries for the specified service exist, or the service is configured to run in the context of the specified user. Start the service manually if the problem persists.

The service '*Service_Name*' did not start within the specified time limit

The agent failed to online the service within the time specified in the DelayAfterOnline attribute.

Recommended Action: Verify the state of the service in the SCM. If the state of the service is START PENDING, increase the time specified in DelayAfterOnline attribute. If the problem persists, start the service manually.

Failed to wait for the service '*Service_Name*' to start. Error = *Error Code*

The agent did not wait for the service to start. This is a VCS internal error. Refer to the documentation specific to the service to determine the cause.

Failed to get the user context of the running service '*Service Name*'. Error = *Error Code*

The agent failed to obtain the information about the user in whose context, the specified service will run.

Recommended Action: Verify that the user exists, or the domain controller is accessible. See the error code if the problem persists.

Failed to get the SID for user '*DomainNameUsername*'

The agent failed to obtain the SID for the specified user.

Recommended Action: Verify that the domain controller is accessible, or the specified user exists. See the error code if the problem persists.

The service '*Service_Name*' is not running under the context of user *DomainNameUsername*

The user information specified in the UserAccount information is different from the user information, in whose context the service will run.

Recommended Action: Stop the service and modify the user information. Re-issue the online command.

The service '*Service_Name*' shares the same process with other services. Killing it might affect those services

If the service has an invalid state, the agent attempts to offline the service. The agent fails to offline the service, if the process is shared with other services. In such cases, the agent attempts to kill the shared process. You risk potential data loss.

Failed to enable the '*Privilege_Name*' privilege. Error = *Error Code*

The agent failed to enable the privilege required to kill a process. See the Windows error code for further information.

Failed to open the service '*Service_Name*'. Error = *Error Code*

The resource definition in the configuration file contains an invalid, or incorrect service name.

Recommended Action: Verify the ServiceName attribute defined in the configuration file is the same as the display name used by SCM. Verify that the specified service was opened successfully.

Failed to query the status of the service '*Service Name*'. Error = *Error Code*

The agent failed to determine the status of the service. This is a VCS internal error.

Recommended Action: Offline and online the service group. Contact Symantec Technical Support if the problem persists.

The service '*Service_Name*' is not in running state. Attempt to stop it might be unsuccessful.

The agent failed to offline the service because the service is not in STARTED state.

Recommended Action: Verify the state of the service and re-issue the online command.

The service '*Service_Name*' did not stop. Error = *Error Code*.

The agent failed to stop the specified service.

Recommended Action: Verify the binaries for the specified service exist, or the service is configured to run in the context of the specified user. Stop the service manually if the problem persists.

The service '*Service_Name*' did not stop within the specified timeout. Error = *Error Code*

The agent failed to offline the service within the time specified in the DelayAfterOffline attribute.

Recommended Action: Verify the state of the service in the SCM. If the state of the service is STOP PENDING, increase the time specified in DelayAfterOffline. If the problem persists, stop the service manually.

ServiceMonitor agent error messages

The ServiceOrScriptName attribute has not been configured

No value specified for the ServiceOrScriptName attribute.

Recommended Action: Verify the ServiceOrScriptName attribute defined in the configuration file is assigned a value.

Failed to lookup the account name '*Account_Name*'. Error = *Error Code*

The agent failed to obtain the SID for the specified user.

Recommended Action: Verify that the domain controller is accessible, or the specified user exists. See the error code if the problem persists.

The password attribute has not been configured

No value specified for the Password attribute.

Recommended Action: Verify the Password attribute defined in the configuration file is assigned a value and contains alphabets only.

Failed to get the password attribute. Error = *Error Code*

The agent failed to decrypt the specified password.

Recommended Action: Verify that the password is encrypted using the VCS Encrypt utility (described in the *Veritas Cluster Server Administrator's Guide*).

Failed to convert the password attribute. Error = *Error Code*

The agent failed to convert the password attribute. This is a VCS internal error.

Recommended Action: Offline and online the service group. Contact Symantec Technical Support if the problem persists.

Failed to open the SCM handle. Error = Error Code

The agent failed to obtain the SCM handle. This occurs if the SCM database does not exist, or if the SCM manager denies the requested access.

Recommended Action: Verify that SCM can be run on the host.

Failed to open the service '*Service_Name*'. Error = Error Code

The resource definition in the configuration file contains an invalid, or incorrect service name.

Recommended Action: Verify that the ServiceOrScriptName defined in the configuration file is the same as the display name used by SCM. Also verify that the specified service is supported by the SCM version on the host and that the specified service was opened successfully.

Failed to query the status of the service '*Service_Name*'. Error = Error Code

The agent failed to determine the status of the service. This is a VCS internal error.

Recommended Action: Verify that the attribute ServiceOrScriptName defined in the configuration file is the same as the display name used by SCM. Otherwise, offline and online the service group. Contact Symantec Technical Support if the problem persists.

The service '*Service_Name*' is not in running state

The agent failed to offline the service because the service is not in STARTED state.

Recommended Action: Verify the state of the service and re-issue the online command.

Failed to get the user context of the running service '*Service_Name*'. Error = Error Code

The agent failed to obtain the information about the user in whose context, the specified service will run.

Recommended Action: Verify that the user exists, or the domain controller is accessible. See the error code if the problem persists.

Failed to get the SID for user '*DomainNameUsername*'

The agent failed to obtain the SID for the specified user.

Recommended Action: Verify that the domain controller is accessible, or the specified user exists. See the error code if the problem persists.

The service '*Service_Name*' is not running under the context of user *DomainNameUsername*

The user information specified in the UserAccount information is different from the user information, in whose context the service will run.

Recommended Action: Stop the service and modify the user information. Re-issue the online command.

Failed to launch the monitor script '*Script_Name*'. Error = *Error Code*

The agent failed to launch the script to monitor the service.

Recommended Action: Verify that the script is accessible. See the Windows error code if the problem persists.

Monitor script has not responded within the specified timeout of *Timeout period* seconds. Error = *Error Code*

The agent failed to receive a response from the monitor script.

Recommended Action: Review the configuration definition of the attribute MonitorProgTimeout. Increase its value if required.

Failed to terminate the monitor program. Error = *Error Code*

The agent failed to terminate the script specified in the *MonitorService* attribute.

Recommended Action: Stop the agent. See the Windows error code, if the problem persists.

Failed to get exit code of the monitor program. Error = *Error Code*

The agent failed to get a response from the script that monitors a specified service.

Recommended Action: Verify that the exit codes returned by the script conform to VCS standards. See the Windows error code for further information. Contact Symantec Technical Support if the problem persists.

Failed to enable the '*Privilege_Name*' privilege. Error = *Error Code*

The agent failed to enable the privilege required to kill a process. See the Windows error code for further information.

Invalid Service name [service_name].

The resource definition in the configuration file contains an invalid or incorrect service name.

Recommended Action: Verify that the attribute ServiceOrScriptName defined in the configuration file is the same as the display name used by SCM. Also verify that the specified service is supported by the SCM version on the host.

Process agent error messages

Failed to convert the argument list. Error = Error Code

The agent failed to convert the argument list. This is a VCS internal error.

Recommended Action: Offline and online the service group. Contact Symantec Technical Support if the problem persists.

Failed to lookup the account name for the user 'Account_Name'. Error = Error Code

The agent failed to obtain the SID for the specified user.

Recommended Action: Verify that the domain controller is accessible, or the specified user exists. See the error code if the problem persists.

The password attribute has not been configured

No value specified for the Password attribute.

Recommended Action: Verify the Password attribute defined in the configuration file is assigned a value and contains alphabets only. If the problem persists, verify that the password is encrypted using the VCS Encrypt utility (described in the *Veritas Cluster Server Administrator's Guide*).

Failed to get the password attribute. Error = Error Code

The agent failed to decrypt the specified password.

Recommended Action: Use the vcencrypt utility to get an encrypted password. Specify the encrypted password to the Password attribute in the configuration file.

Failed to convert the password attribute. Error = Error Code

The agent failed to convert the password attribute. This is a VCS internal error.

Recommended Action: Offline and online the service group. Contact Symantec Technical Support if the problem persists.

StartProgram has not been configured

No value specified for the StartProgram attribute.

Recommended Action: Verify the StartProgram attribute defined in the configuration file is assigned a value.

The process (*Process ID*) is not alive. Error = Error Code

The process specified in the StartProgram attribute is not alive.

Recommended Action: Verify the StartProgram attribute defined in the configuration file is assigned a value. See the Windows error code if the problem persists.

Failed to get cmd line of the process(*Process_ID*). Error= Error Code

The agent failed to determine the command line string for the process mentioned in the StartProgram attribute.

Recommended Action: Verify the StartProgram attribute defined in the configuration file is assigned a value. See the Windows error code if the problem persists.

The command line of the process(*Process_ID*) does not match with that configured in the attributes

The command line of the process, determined by the agent, did not match with the command line specified in the StartProgram attribute.

Recommended Action: Verify the StartProgram attribute defined in the configuration file is assigned a correct value.

Failed to get the user context of the process(*Process_ID*). Error= Error Code

The agent failed to obtain the information about the user in whose context, the specified process will run.

Recommended Action: Verify that the user exists, or the domain controller is accessible. See the error code if the problem persists.

The user context of the process (*Process_ID*) does not match with that configured in the attributes

The user context of the process, determined by the agent, did not match with the user context specified in the UserName attribute.

Recommended Action: Verify the UserName attribute defined in the configuration file is assigned a correct value.

Failed to determine whether the process is running or not. Error = Error Code

The agent failed to determine whether the process specified in the StartProgram attribute is running.

Recommended Action: Verify the StartProgram attribute defined in the configuration file is assigned a value. See the Windows error code if the problem persists.

Failed to enable '*Privilege_Name*' privilege. Error = Error Code

The agent failed to enable the privilege required to kill a process. See the Windows error code for further information.

Failed to launch the program '*Program_Name*'. Error = Error Code

The agent failed to launch the program specified in the StartProgram, CleanProgram, MonitorProgram, or StopProgram attributes.

Recommended Action: Verify the attributes defined in the configuration file are assigned a value. See the Windows error code if the problem persists.

Failed to get command line of the process (*Process_ID*). Error= Error Code

The agent failed to determine the command line of the process.

Recommended Action: Verify the attributes defined in the configuration file are assigned a value. See the Windows error code if the problem persists.

Failed to wait for the process (*Process_ID*) to stop. Error = Error Code. Killing it

The process specified in the StartProgram, CleanProgram, MonitorProgram, or StartProgram attribute did not respond in the specified timeout. The agent will try to kill the process.

Recommended Action: Increase the timeout specified in the MonitorProgramTimeout attribute. See the Windows error code if the problem persists.

Failed to get the ACL information. Error = Error Code

The agent failed to retrieve the Access Control List of the interactive desktop and window station.

Recommended Action: See the Windows error code for more information. Contact Symantec Technical Support if the problem persists.

Failed to get the ACE. Error = *Error Code*

The agent failed to retrieve the Access Control Entry for the ACL of the interactive desktop and window station.

Recommended Action: See the Windows error code for more information. Contact Symantec Technical Support if the problem persists.

Failed to add an ACE entry. Error = *Error Code*

The agent failed to add an ACE to the ACL of the interactive desktop and window station.

Recommended Action: See the Windows error code for more information. Contact Symantec Technical Support if the problem persists.

Troubleshooting infrastructure and support agents

Infrastructure and Support agents comprise NotifierMngr agent, Registry Replication agent, Proxy agent, Phantom agent, FileNone agent, ElifNone agent, FileOnOff agent, and FileOnOnly agent.

Notifier Manager agent error messages

Failed to Start Notifier Process *Process_ID*. (Windows Error Code = *Error Code*)

The agent failed to start the specified notifier process. This could occur due to an incorrect path name specified in the configuration, low memory on the system, or a Windows-specific error, defined by the corresponding error code.

Recommended Action: Verify the configuration definition of the agent. Verify that the system has adequate memory.

Failed to Open Notifier Process. PID = *Process_ID* (Windows Error Code = *Error Code*)

The notifier process was terminated.

Recommended Action: VCS marks the resource as faulted. Wait, then try to bring the resource online again.

Failed to Offline Notifier Process. PID = *Process_ID* (Windows Error Code = *Error Code*)

The agent could not terminate the notifier process. This indicates a Windows-specific error, defined by the corresponding error code.

Recommended Action: Try terminating the process manually using Task Manager.

Failed to Clean Notifier Process. PID = *Process_ID* (Windows Error Code = *Error Code*)

The agent could not terminate the notifier process. This indicates a Windows-specific error, defined by the corresponding error code.

Recommended Action: Try terminating the process manually using Task Manager.

Invalid SNMP severity specified

Invalid severity level specified for SNMP notifications,

Recommended Action: Verify the severity level specified in the SnmpConsoles attribute has “Warning”, “Information”, “Error”, or “SevereError” as the severity level.

Invalid SMTP severity specified

Invalid severity level specified for SMTP notifications,

Recommended Action: Verify the severity level specified in the SmtpRecipients attribute has “Warning”, “Information”, “Error”, or “SevereError” as the severity level.

Expected correct SNMP and | or SMTP options

Invalid values specified for SNMP and SMTP attributes.

Recommended Action: Verify the attributes defined in the configuration file are assigned valid values.

Unable to online resource. Please specify correct SNMP and | or SMTP options

Invalid values specified for SNMP and SMTP attributes.

Recommended Action: Verify the attributes defined in the configuration file are assigned valid values.

Unable to find VCS_HOME. Error Code = Error Code

The value for VCS_HOME environment variable is incorrect.

Recommended Action: Verify the value for the VCS_HOME environment variable. Contact Symantec Technical Support if the problem persists.

Registry Replication agent error messages

Directory does not exist (or) could not create (directory=Drive name:path)

The registry replication directory specified in the configuration either does not exist or could not be created.

Recommended Action: Verify that the shared drive is accessible, and that no file in that drive has the same name as that of the ReplicationDirectory attribute. Also, verify whether the required permissions are available to create the directory.

The name of the local host is invalid (hostname= *host_name*)

This is a VCS internal error.

Recommended Action: Verify that the local host has a valid name. Contact Symantec Technical Support if the problem persists.

Failed to restore the registry (key= *Key_name*, filename= *File_name*). Possibly some applications might have keys open eg.,REGEDIT.EXE. Please close them.

The agent failed to restore the specified registry key.

Recommended Action: Close the application that accesses the specified registry keys. Contact Symantec Technical Support if the problem persists.

Duplicate key (or) Already part of notification (key=*Key_name*)

The specified registry key is already specified in the configuration.

Recommended Action: Verify that the values specified in Keys and ExcludeKeys attribute are unique.

Could not locate the file (file=*file_name*)

The agent was unable to locate the registry replication files.

Recommended Action: Verify that the files exist in the directory.

Failed to set %s

The agent failed to enable debug monitoring.

Recommended Action: Verify that monitor.exe is running. Contact Symantec Technical support if the problem persists.

Agent module and Registry-change-monitor module are not of the same version (received= %s, expected=%s)

The Registry Replication agent consists of two modules: Registry Replication and Registry Monitoring. If the versions of these modules are different, the agent will not come online.

Recommended Action: Verify the version of both agent modules. Contact Symantec Technical Support if problem persists.

Configuration Error : Key '*Key_name*' is configured in Replication Key List as well as in Exclude Key List

The specified key is configured both for Keys and ExcludeKeys attribute.

Recommended Action: Verify the configuration definition of the attributes Keys and ExcludeKeys. Make sure a specific key is not defined for both the attributes.

Configuration Error : Key '*Key_name*' configured in Replication Key List is a Sub Key of key '*Key_name*' configured in Exclude Key List

The specified key is configured for replication while its super key is configured for exclusion.

Recommended Action: Verify the configuration definition of the attributes Keys and ExcludeKeys.

Proxy agent error messages

Target Resource Name is not a valid name

The resource name specified in the TargetResName attribute is invalid.

Recommended Action: Verify the TargetResName attribute defined in the configuration file is assigned a correct value.

Target resource is not Probed

The agent cannot monitor the target resource because the target resource has not been probed.

Recommended Action: Verify that the target resource has been probed. To get the probed status of the target resource, execute `hares -display` from the command prompt.

Phantom agent error message

Contact Symantec Technical Support for any errors associated with the Phantom agent.

FileNone agent error message

File Name is not specified

The configuration file does not contain the path name, or the configured path name is incorrect.

Recommended Action: Verify that the attribute PathName is correctly defined in the configuration file.

ElifNone agent error message

FileName is not valid

The configuration file does not contain the path name, or the configured path name is incorrect.

Recommended Action: Verify that the attribute PathName is correctly defined in the configuration file.

FileOnOff agent error messages

Unable to create the file

The agent was unable to create the specified file.

Recommended Action: Verify that the filename specified in the PathName attribute does not contain any special characters, and the directory where the file will be created, exists on the node.

Unable to delete the file

The agent was unable to delete the specified file.

Recommended Action: Verify the filename specified in the PathName attribute exists, and the file is not locked by another user.

FileOnOnly agent error messages

ERROR! FileName is not valid

The configuration file does not contain the path name, or the configured path name is incorrect.

Recommended Action: Verify that the attribute PathName is correctly defined in the configuration file.

Unable to create the file

The agent was unable to create the specified file.

Recommended Action: Verify that the filename specified in the PathName attribute does not contain any special characters, and the directory where the file will be created, exists on the node.

Troubleshooting NetApp agents

This section describes the error messages for the VCS NetApp agents.

Failed to open connection to filer %s.

Recommended Action: Make sure that the VCS Helper Service account has domain admin privileges and is part of the administrator's group on the local host and the filer.

Make sure the private network is functioning properly. Verify you can ping the IP used for the private storage network. This is the IP defined the StorageIP attribute of the NetAppFiler resource.

Failed to initialize ONTAPI on system

The agent could not find the file NTAPADMIN.DLL on the system.

Recommended Action: Verify the file exists in the %VCS_HOME%\bin directory.

Invalid attributes exist in the configuration

Some agent attributes have not been defined or have been defined incorrectly.

Recommended Action: Verify the configuration definition for the agent.

ONTAP API called failed for object_name on filer_name.

The specified API failed on the specified object.

Recommended Action: See the NetApp ONTAP API documentation for information about the associated error message

Volume %s on filer %s is not a SnapMirror replicated volume

Recommended Action: Verify replication is set up on the specified volume.

Multiple snapmirror destinations for a volume is not supported by this agent. 'snapmirror status' for volume %s on filer %s returned multiple status entries. Administrative intervention required

Recommended Action: There should be only one destination per source volume.

Initialize VLibNetAppHost::Initialize() failed. (error_type: %s, error_code: 0x%s)

The agent could not detect the iSCSI or the FC Initiator on the host.

Recommended Action: Make sure that you have installed and configured Microsoft iSCSI Initiator or an FC Initiator on each node.

Failed to connect/disconnect virtual disk. (error_type: %s, error_code: 0x%s, error_message: %s)

This could occur because one or more of the following parameters are defined incorrectly in the VCS configuration:

- Filer name
- Volume name/LUN name
- Share name
- Storage IP

Recommended Action: Verify the configuration definition of the resource. Make sure each attribute is defined correctly.

Unable to create/delete online lock file %s. Error code %s,

Recommended Action: Make sure you have write permissions on the specified directory.

Index

A

- ABE 83, 95
- Access-based Enumeration 83, 95
- agent functions
 - CompositeFileShare 86
 - DiskRes 25
 - ElifNone 156
 - FileNone 155
 - FileOnOnff 157
 - FileOnOnly 158
 - FileShare 73
 - GenericService 115
 - IIS 107
 - IP 50
 - IPv6 52
 - Lanman 56
 - Mount 28
 - MSMQ 132
 - NetApp Filer 173
 - NetApp SnapDrive 175
 - NetApp SnapMirror 177
 - NIC 46
 - NotifierMngr 137
 - Phantom 154
 - PrintShare 102
 - PrintSpool 99
 - Process 125
 - Proxy 151
 - RegRep agent 142
 - RemoteGroup 159
 - ServiceMonitor 119
 - VMDg 33
- agent log
 - format 184
 - location 184
- agents
 - CompositeFileShare 85
 - DiskReservation 24
 - ElifNone 156
 - FileNone 155
 - FileOnOff 157
 - FileOnOnly 158
 - FileShare 72
 - GenericService 115
 - IIS 107
 - IP 50
 - IPv6 52
 - Lanman 55
 - Mount 28
 - MountV 38
 - MSMQ 132
 - NetApp Filer 173
 - NetApp SnapDrive 175
 - NetApp SnapMirror 177
 - NIC 46
 - NotifierMngr 137
 - Phantom 154
 - PrintShare 102
 - PrintSpool 98
 - Process 125
 - Proxy 151
 - RegRep 142
 - RemoteGroup 159
 - ServiceMonitor 119
 - VMDg 33
- application agents
 - IIS agent 107
- asynchronous replication 180
- attribute definitions
 - CompositeFileShare agent 88
 - DiskRes agent 25
 - ElifNone agent 156
 - FileNone agent 155
 - FileOnOff agent 157
 - FileOnOnly agent 158
 - FileShare agent 76
 - GenericService agent 116
 - IIS agent 108
 - IP agent 51
 - IPv6 agent 53
 - Lanman agent 58
 - Mount agent 30
 - MountV agent 40

- MSMQ agent 133
- NIC agent 48
- NotifierMngr agent 138
- Phantom agent 154
- PrintShare agent 103
- PrintSpool agent 99
- Process agent 126
- Proxy agent 152
- RegRep agent 145
- RemoteGroup agent 161
- ServiceMonitor agent 122
- VMDg agent 34
- attributes
 - data types 17
 - dimensions 18
 - for NetApp Filer agent 173
 - for NetApp SnapDrive agent 176
 - for NetApp SnapMirror agent 179

B

- bundled agents
 - categories 19
 - definition of 16

C

- CheckFSAccess 42
- CompositeFileShare agent
 - access-based enumeration 95
 - agent functions 86
 - attribute definitions 88
 - dependencies 85
 - description 85
 - error messages 213
 - ForceControl 86
 - sample configuration 96
 - state definitions 86
 - type definition 87

D

- DiskReservation agent
 - agent functions 25
 - attribute definitions 25
 - description 24
 - error messages 185
 - sample configuration 26
 - state definitions 25
 - type definition 25

- DNS servers, updating 68

E

- ElifNone agent
 - agent functions 156
 - attribute definitions 156
 - description 156
 - error messages 240
 - sample configuration 156
 - state definitions 156
 - type definition 156
- error messages
 - agent log 184
 - See Also troubleshooting

F

- fbsync 178
- FileNone agent
 - agent functions 155
 - attribute definitions 155
 - description 155
 - error messages 240
 - sample configuration 155
 - state definitions 155
 - type definition 155
- FileOnOff agent
 - agent functions 157
 - attribute definitions 157
 - description 157
 - error messages 241
 - sample configuration 157
 - state definitions 157
 - type definitions 157
- FileOnOnly agent
 - agent functions 158
 - attribute definitions 158
 - description 158
 - error messages 241
 - sample configurations 158
 - state definitions 158
 - type definition 158
- FileShare agent
 - access-based enumeration 83
 - agent functions 73
 - attribute definitions 76
 - dependencies 72
 - description 72
 - error messages 212

- ForceControl 74
 - sample configuration 83
 - state definitions 73
 - type definition 75
- FileShare agents
 - CompositeFileShare agent 85
 - FileShare agent 72
- ForceControl 74, 86

G

- GenericService agent
 - agent functions 115
 - attribute definitions 116
 - description 115
 - error messages 224
 - sample configuration 118
 - state definitions 115
 - type definition 116

I

- IIS agent
 - agent functions 107
 - attribute definitions 108
 - description 107
 - error messages 221
 - sample configurations 111
 - state definitions 107
 - type definition 107

IMF

- GenericService 115
- IIS 107
- IP 50
- Mount 28
- MountV 38
- NIC 46
- Process 125
- RegRep 142
- ServiceMonitor 119
- VMDg 33
- infrastructure and support agents
 - ElifNone agent 156
 - FileNone agent 155
 - FileOnOff 157
 - FileOnOnly 158
 - NotifierMngr agent 137
 - Phantom agent 154
 - Proxy agent 151
 - RegRep agent 142

- RemoteGroup agent 159
- IP agent
 - agent functions 50
 - attribute definitions 51
 - dependency 50
 - description 50
 - error messages 206
 - sample configuration 51
 - state definitions 50
 - type definition 50
- IPv6 agent
 - agent functions 52
 - attribute definitions 53
 - dependency 52
 - description 52
 - sample configuration 54
 - state definitions 52
 - type definition 53

L

- Lanman agent
 - agent functions 56
 - attribute definitions 58
 - changing dependency 56
 - dependency 55
 - description 55
 - error messages 208
 - sample configuration 69
 - state definitions 56
 - type definition 57
 - updating DNS servers 68
- logging
 - agent log 184

M

- Mount agent
 - agent functions 28
 - attribute definitions 30
 - dependency 28
 - description 28
 - error messages 190
 - sample configuration 32
 - state definitions 28
 - type definition 30
- MountV agent
 - agent functions 38
 - attribute definitions 40
 - CheckFSAccess 42

- dependency 38
 - description 38
 - error messages 200
 - sample configuration 43
 - state definitions 39
 - type definition 39
- MSMQ agent
 - attribute definitions 133
 - dependencies 132
 - description 132
 - sample configuration 134
 - state definitions 133
 - type definition 133
- N**
- NetApp agents
 - error messages 242
 - NetApp Filer 173
 - NetApp SnapDrive 175
 - NetApp SnapMirror 177
- NetApp Filer agent
 - attributes 173
 - functions 173
 - sample configuration 173
 - type definition 173
- NetApp SnapDrive agent
 - attributes 176
 - dependencies 175
 - functions 175
 - sample configuration 176
 - type definition 175
- NetApp SnapMirror agent
 - attributes 179
 - dependency 177
 - functions 177
 - sample configuration 181
 - type definition 178
- NetAppSnapMirror
 - fbsync 178
- network agents
 - IP agent 50
 - IPv6 agent 52
 - Lanman agent 55
 - NIC agent 46
- NIC agent
 - agent functions 46
 - attribute definitions 48
 - description 46
 - error messages 204
 - sample configuration 49
 - state definitions 47
 - type definition 47
- NotifierMngr agent
 - agent functions 137
 - attribute definitions 138
 - description 137
 - error messages 236
 - state definitions 137
 - type definition 138
- P**
- Phantom agent
 - agent functions 154
 - description 154
 - error messages 240
 - sample configuration 154
 - state definitions 154
- PrintShare agent
 - agent functions 102
 - attribute definitions 103
 - dependency 102
 - description 102
 - error messages 219
 - sample configuration 103
 - state definitions 102
 - type definition 102
- PrintShare agents
 - PrintShare agent 102
 - PrintSpool agent 98
- PrintSpool agent
 - agent functions 99
 - attribute definitions 99
 - dependencies 98
 - description 98
 - error messages 216
 - sample configuration 100
 - state definitions 99
 - type definition 99
- Process agent
 - agent functions 125
 - attribute definitions 126
 - description 125
 - error messages 231
 - sample configuration 131
 - state definitions 125
 - type definition 126
 - using batch files 131
- Proxy agent

- agent functions 151
- attribute definitions 152
- description 151
- error messages 240
- state definitions 151
- type definition 151

R

- registry keys
 - abbreviations 148
 - configuring 148
 - excluding 148
- RegRep agent
 - agent functions 142
 - attribute definitions 145
 - configuring registry keys 148
 - dependency 142
 - description 142
 - error messages 237
 - excluding registry keys 148
 - sample configuration 149
 - state definitions 144
 - type definition 144
- RemoteGroup agent
 - agent functions 159
 - attribute definitions 161
 - description 159
 - state definitions 160
 - type definition 161
- replication modes 180
- resource type
 - NetApp Filer agent 173
 - NetApp SnapDrive agent 175
 - NetApp SnapMirror agent 178
- resource type definition
 - CompositeFileShare agent 87
 - DiskRes agent 25
 - ElifNone agent 156
 - FileNone 155
 - FileOnOff agent 157
 - FileOnOnly agent 158
 - FileShare agent 75
 - GenericService 116
 - IIS agent 107
 - IP agent 50
 - IPv6 agent 53
 - Lanman agent 57
 - Mount agent 30
 - MountV agent 39

- MSMQ agent 133
- NIC agent 47
- NotifierMngr agent 138
- PrintShare agent 102
- PrintSpool agent 99
- Process agent 126
- Proxy agent 151
- RegRep agent 144
- RemoteGroup agent 161
- ServiceMonitor 121
- VMDg agent 33

S

- semi-synchronous replication 180
- ServiceMonitor agent
 - agent functions 119
 - attribute definitions 122
 - description 119
 - error messages 228
 - sample configurations 124
 - state definitions 119
 - type definition 121
- services agents
 - GenericService agent 115
 - MSMQ agent 132
 - Process agent 125
 - ServiceMonitor agent 119
- state definitions
 - CompositeFileShare agent 86
 - DiskRes agent 25
 - ElifNone agent 156
 - FileNone agent 155
 - FileOnOff agent 157
 - FileOnOnly agent 158
 - FileShare agent 73
 - GenericService agent 115
 - IIS agent 107
 - IP agent 50
 - IPv6 agent 52
 - Lanman agent 56
 - Mount agent 28
 - MountV agent 39
 - MSMQ agent 133
 - NIC agent 47
 - NotifierMngr agent 137
 - Phantom agent 154
 - PrintShare agent 102
 - PrintSpool agent 99
 - Process agent 125

- Proxy agent 151
- RegRep 144
- RemoteGroup agent 160
- ServiceMonitor agent 119
- VMDg agent 33
- storage agents
 - DiskRes agent 24
 - Mount agent 28
 - MountV agent 38
 - VMDg agent 33
- synchronous replication 180

T

troubleshooting

- CompositeFileShare agent 213
- DiskReservation agent 185
- ElifNone agent 240
- FileNone agent 240
- FileOnOff agent 241
- FileOnOnly agent 241
- FileShare agent 212
- GenericService agent 224
- IIS agent 221
- IP agent 206
- Lanman agent 208
- logging 184
- Mount agent 190
- MountV agent 200
- NetApp agents 242
- NIC agent 204
- NotifierMngr agent 236
- Phantom agent 240
- PrintShare agent 219
- PrintSpool agent 216
- Process agent 231
- Proxy agent 240
- RegRep agent 237
- ServiceMonitor agent 228
- VMDg agent 198

type definition

- NetApp Filer agent 173
- NetApp SnapDrive agent 175
- NetApp SnapMirror agent 178

type definition. See resource type definition

V

VCS

- about bundled agents 16

- logging 184
- Volume Manager Diskgroup agent (VMDg)
 - agent functions 33
 - attribute definitions 34
 - description 33
 - error messages 198
 - sample configuration 37
 - state definitions 33
 - type definition 33